

AOS™

ADVANCED ORTHOPAEDIC SOLUTIONS

0, 1, 1, 2, 3, 5, 8, 13, 21, 34, 55, 89, 144, 233, 377, 610, 987, 1597, 2584, 4181, 6765, 10946, 17711, 28657

The Fibonacci sequence is a series of numbers where a number is found by adding up the numbers before.

series of a by adding up the numbers before.

1, 1, 2, 3, 5, 8, 13, 21, 34,

the sequence starts with 1, 1, and so on. The expression is $k_n = k_{n-1} + k_{n-2}$.

Named after Fibonacci, also known as Leonardo of Pisa, or Leonardo, his Fibonacci numbers were produced in his book 'The Book of Squares' in 1202.

Fibonacci and traded very important to those in the industry, and his passion for numbers was cultivated in his youth.

Fibonacci™

LOWER EXTREMITY PLATING SYSTEM
Surgical Technique



Advanced Orthopaedic Solutions
3203 Kashiwa Street
Torrance, CA 90505

T: 310.533.9966
F: 310.533.9876
www.aosortho.com



Contents

IMPLANT FEATURES	2-3
1. INDICATIONS	4
2. PREPARATION	4
3. PLATE SELECTION	5
4. PLATE BENDING	5-6
5. REDUCTION AND TEMPORARY PLATE FIXATION	7-9
6. FINAL PLATE FIXATION	9
7. INSERTING SCREWS	10-12
8. NON-LOCKING SCREWS	13
9. LOCKING SCREWS	14
10. CANNULATED SCREW	15
11. CONFIRM REDUCTION AND FIXATION	16
12. POSTOPERATIVE TREATMENT	16

This Surgical Technique sets forth detailed recommended procedures for using AOS devices and instruments. It offers guidance, but as with any such technical guide, each surgeon must consider the particular needs of each patient and make appropriate adjustments when and as required. Surgeons must always rely on their own professional clinical judgement when deciding which products and surgical treatments to use with their patients. Refer to package insert for information on indications, warnings, precautions and contraindications.

Implant Features



2.4mm Non-Locking Cortical



2.7mm Locking Cortical



2.7mm Non-Locking Cortical



3.5mm Locking Cortical



3.5mm Non-Locking Cortical

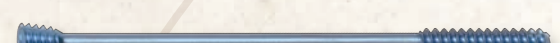

3.5mm Cannulated Headless Compression, 1/4 Thread



3.5mm Cannulated Headless Compression, 1/2 Thread



4.0mm Non-Locking Cancellous, Fully Threaded

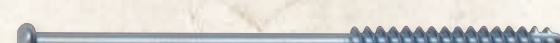

4.0mm Non-Locking Cancellous, Partially Threaded

Advanced Orthopaedic Solutions designs, manufactures, and markets orthopaedic trauma products, specializing in intramedullary fixation devices for minimally invasive surgical procedures. We rely on surgeon input to create solutions which are less invasive, more cost effective, and reduce surgical course. We rely on the expertise of the developing new instruments minimally invasive, productive our surgeon champions work with universities.

ABS is entirely focused on the distal. We base our success on the expertise of the developing new instruments minimally invasive, productive our surgeon champions work with universities.

Our team enables development of product solutions that are then manufactured.

state of the art methods and practices that are compliant with US and International quality systems. Moreover, ABS products are distributed world wide through independent distributors and agents. ABS continues every aspect of our business.



Anterior Delta Plates

Anterior Cortical Rim Plates

Straight Plates

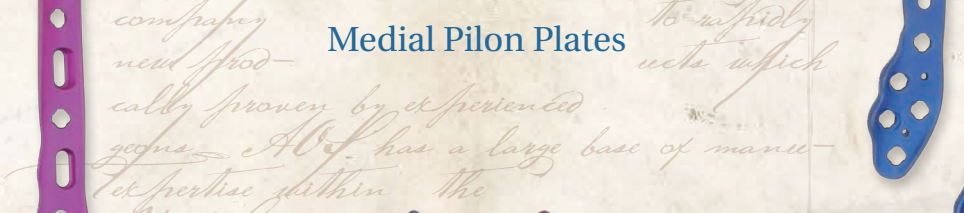

Medial Pilon Plates



Distal Posterior Fibula Plates



Distal Lateral Fibula Plates

Posterior Tibia Plates



Distal Anterolateral Tibia Plates



L-Plates



T-Plates

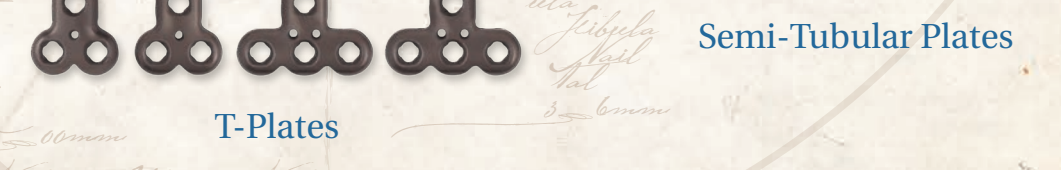

Semi-Tubular Plates

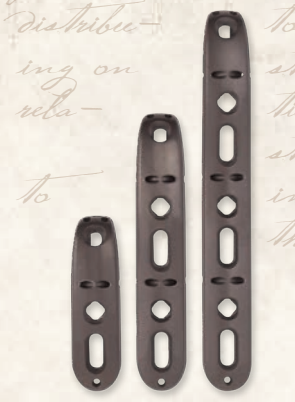

Distal Hook Plates

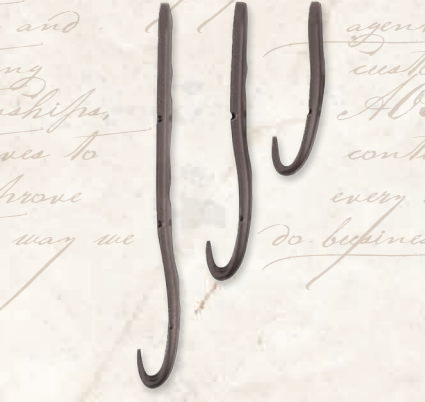

Distal Hook Plates Profile

2 → 5mm Fibula
3 → 6mm Fibula
Radius Nail
Distal Diameter 3-6mm
4 → 6mm
5 → 60mm
Radius Nail
Ulna Nail

2 → 5mm Fibula
3 → 6mm
Radius Nail
Distal Diameter 3-6mm
4 → 6mm
5 → 60mm
Radius Nail
Ulna Nail

Fibonacci Lower Extremity Plating System Surgical Technique

1. Indications

The AOS Small Fragment Plating System is intended to be used for fixations of fractures, osteotomies, and non-unions of the clavicle, scapula, olecranon, humerus, radius, ulna, pelvis, distal tibia, fibula, including osteopenic bone.

2. Preparation

Prior to initiating the reduction and fixation of any fracture, fluoroscopy and/or CT scan should be used to properly assess the injury and plan the procedure. Due to the modularity of the Fibonacci Lower Extremity Plating System and the variety of fracture types (Fig. 1) that this system can be used to fix, plate selection, incision, and patient positioning will vary on a case-by-case basis.

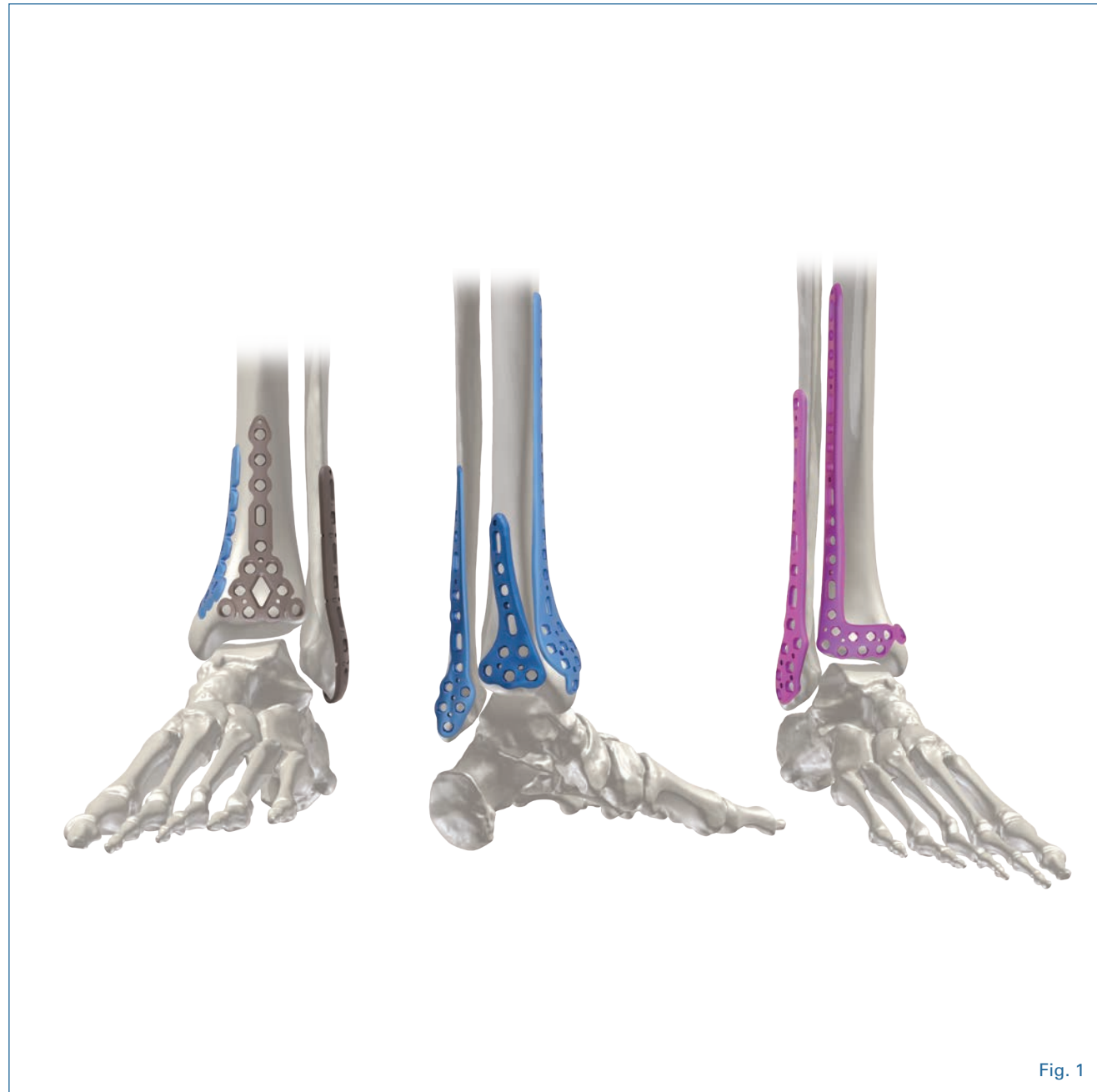

Fig. 1

3. Plate Selection

Based on patient anatomy, fracture location and type, select a plate shape and design contour that will provide optimum fit and fixation (See "Implant Features" (pg. 2-3) for plate options).

Note: Some of the plates provided in this system are pre-contoured for specific anatomical placement. It is important to verify that the shape and contour of the plate selected will provide desired placement on to the bone and fracture fixation without altering proper anatomical reduction.



Fig. 2a



Fig. 2b

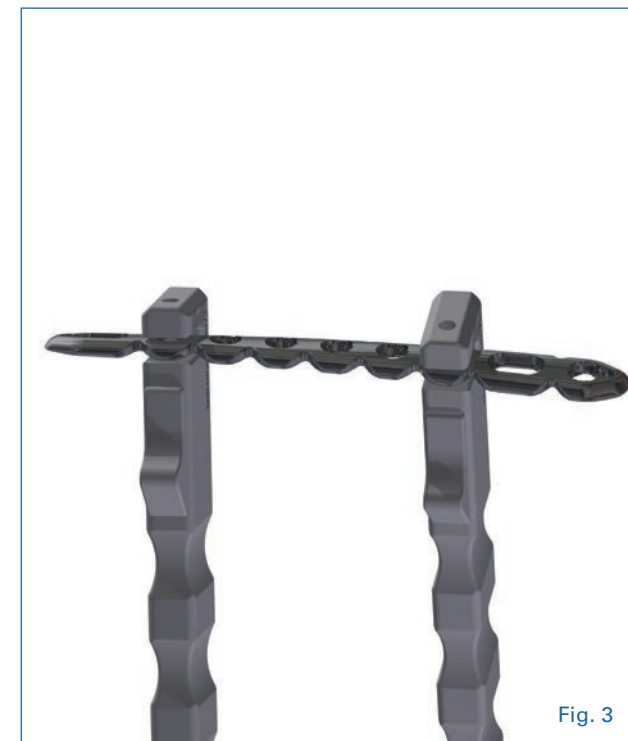

Fig. 3

4. Plate Bending

In some circumstances, some slight plate bending may be necessary. This is achieved using **Bending Irons** or the **Handheld Plate Bender** included in the instruments. Based on your preference of plate bending instrumentation, contour the plate as needed for an optimum fit.

Note: Notched plates are designed to bend at the notch.

Bending Irons - The bending irons are designed to be used with the straight plates and have three (3) different opening options to bend the plates:

1. Transverse or perpendicular openings
2. Diagonal openings
3. Parallel openings

Simple plate bending (Fig. 2a, 2b) or longitudinal twisting (Fig. 3) is achieved using any paired combination of bending iron openings.

Handheld Plate Bender - The handheld plate bender can be used with all flat non-pre-contoured plates that have notches and can either bend or curve the plate:

1. Bending the plate – place an edge of the plate into the slot and squeeze handle grip until desired bend is achieved (Fig. 4a, 4b).

2. Curving the plate – place the plate bottom into the plate bender so that the manufactured notch is at the desired bend location and the beveled top of the plate is facing up. Make sure that the plate is seated properly and then squeeze the handle grip until desired curve is achieved (Fig. 5a, 5b).

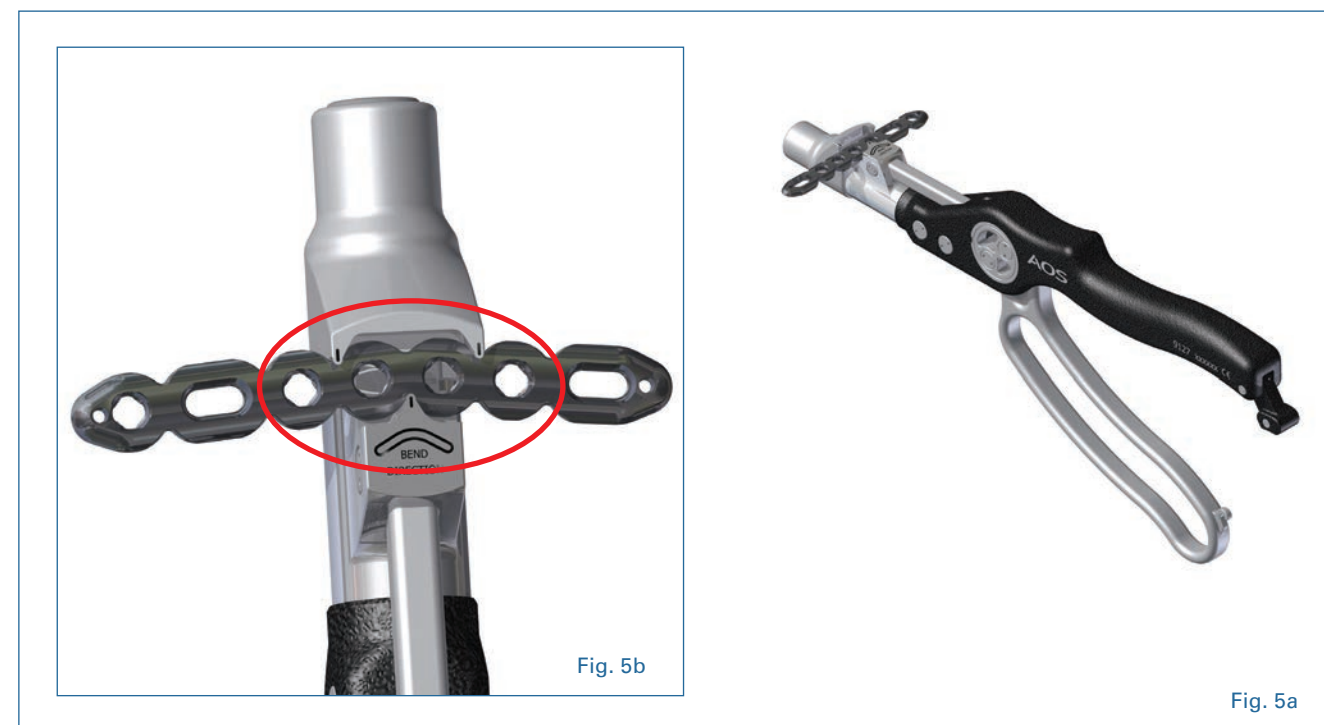
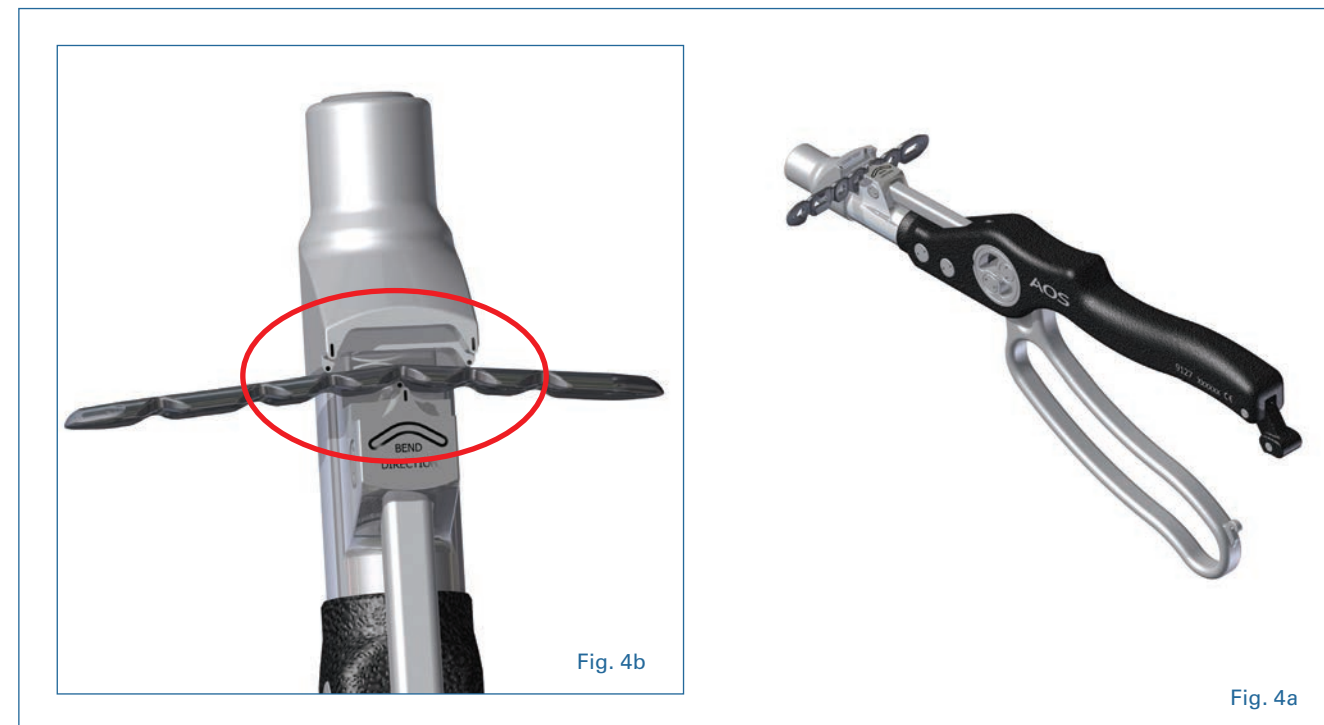

5. Reduction and Temporary Plate Fixation

If the fractured bone ends are angled or oblique, reduction with a pointed or serrated reduction forceps is recommended. Normal length, axis angulation and rotation should be restored. Any large comminuted fragments should also be reduced and temporarily held with small pointed bone clamps or K-Wires.

Note: Plan temporary fixation so that it does not interfere with the placement of definitive fixation.

Place the selected plate onto the stable portion of the fracture where it is determined to initiate the fracture reduction. The holes in the plate are tapered to allow for up to 10° of angulation in any direction (Fig. 6a, 6b) when using K-Wires for temporary fixation. Two (2) types of K-Wires are provided in the set of instrumentation (Fig. 7).

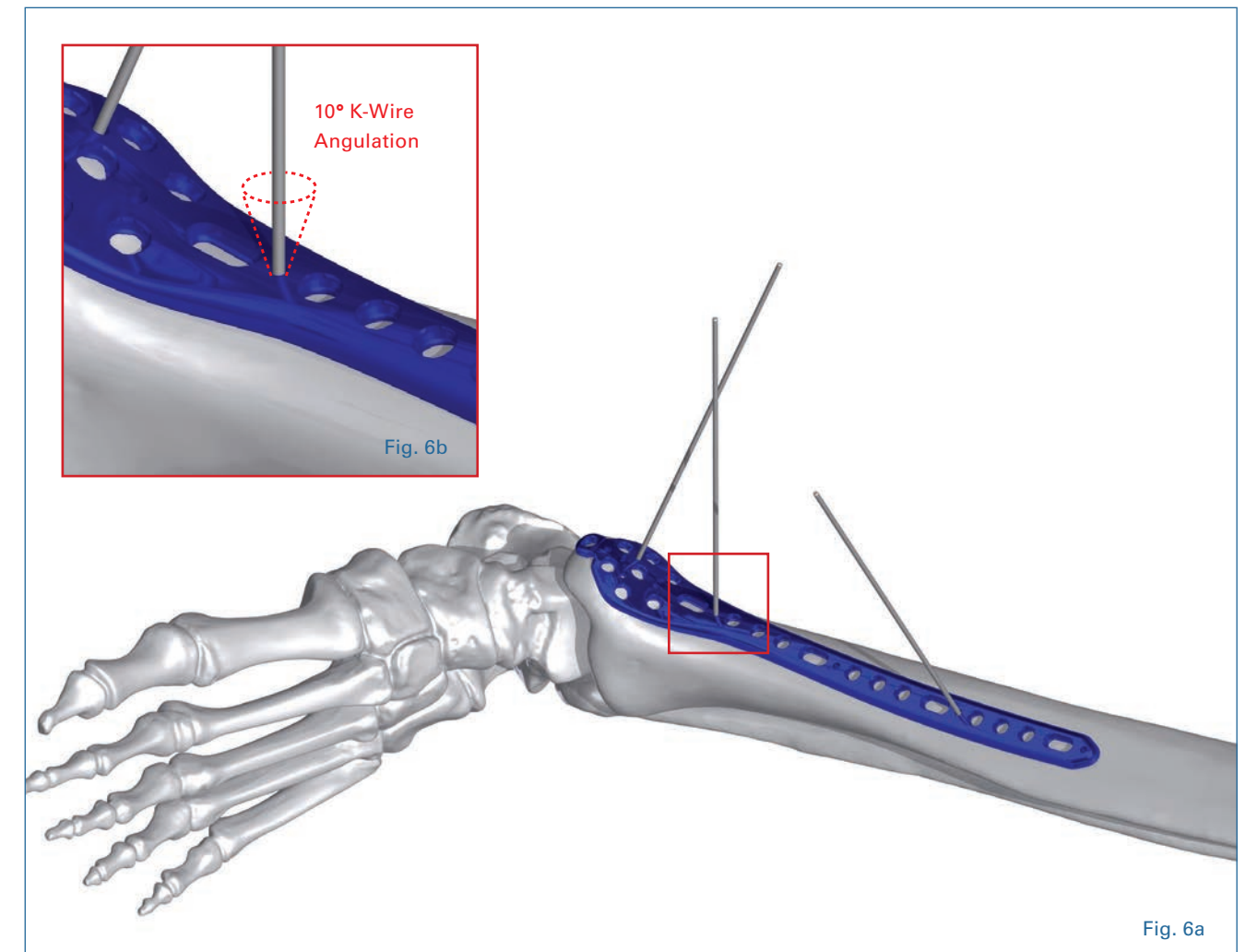

The following suggestions are some additional methods that can be used for temporary fixation of the selected plate on the fracture as considered appropriate for each specific fracture.

Lobster Claw(s) with K-Wire holding plate (Fig. 8).
Non-locking screw through the oblong holes in the plate (Fig. 9).

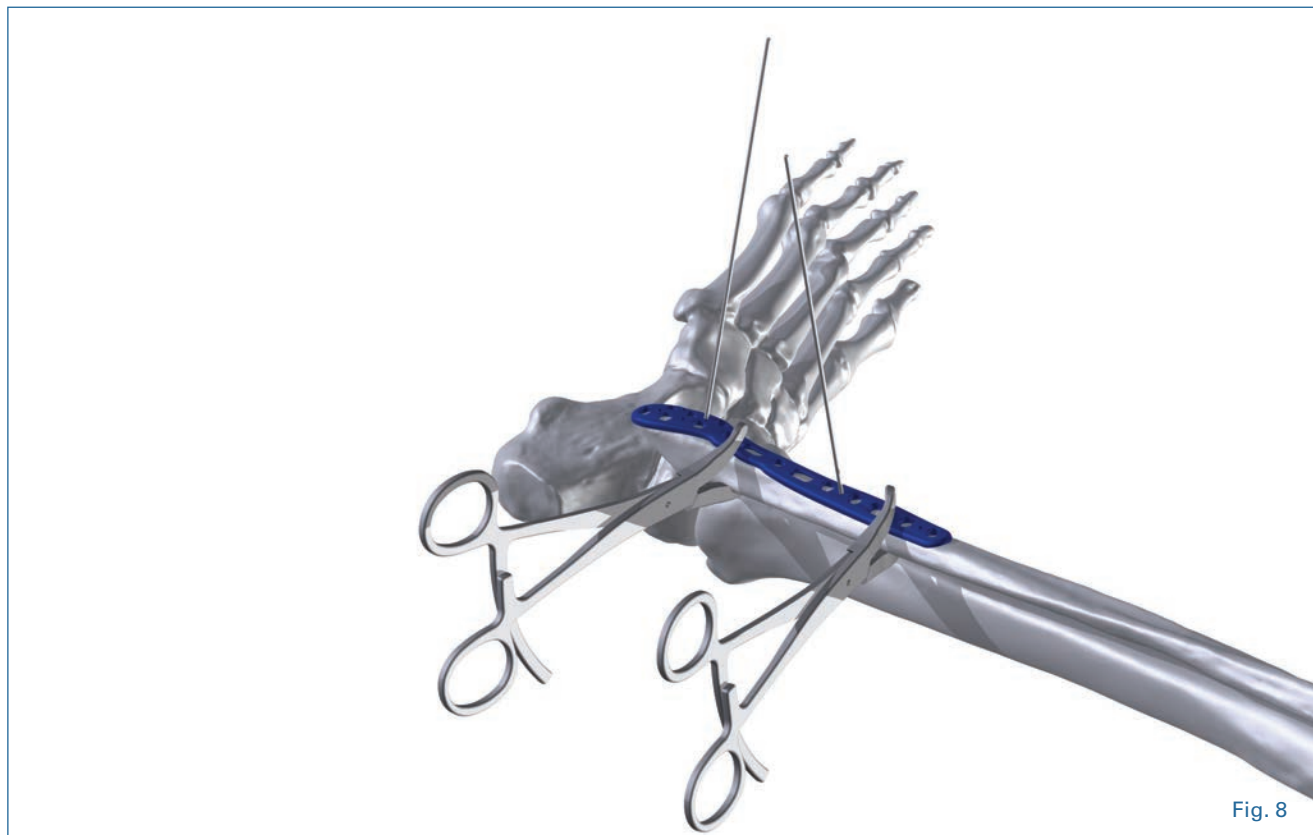

Temporary Fixation Pin (Fig. 10a, 10b, 10c).
Modified Verbrugge (plate holder) clamp (Fig. 11).

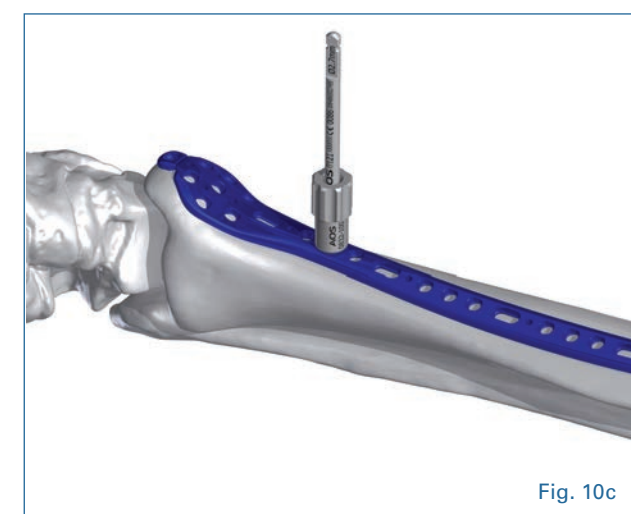
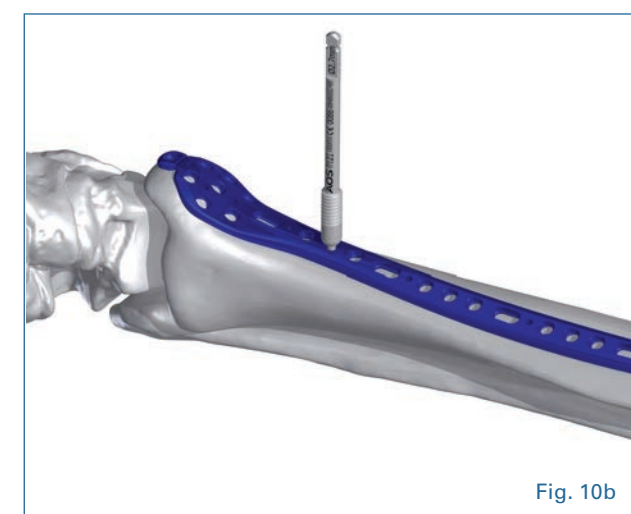
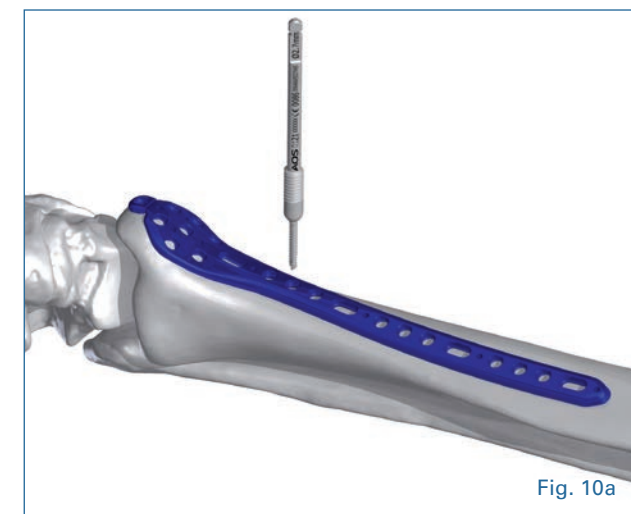

6. Final Plate Fixation

With the temporary plate fixation secured, check the alignment of the fracture and the plate both visually and using radiographic imaging. If desired reduction and plate position is achieved then definitive plate fixation can begin.

7. Inserting Screws

Note: To secure the plate to the bone prior to using locking screw insertion, it is recommended to pull the plate to the bone using a non-locking screw. If a combination of locking and non-locking screws will be used, non-locking screws should be inserted first to ensure that the plate has appropriate bone contact.

Select desired screw type (Fig. 12) and insert screw(s) using surgeon preferred screw hole selection on the plate.

Note: Two (2) Fixed Angle Drill Guide (1.9mm and 2.5mm) and three (3) Variable Angle Drill Guides (1.9mm, 2.5mm, and 3.5mm) are available in this system. Based on preference a Screw Sheath can be used with drill guides.

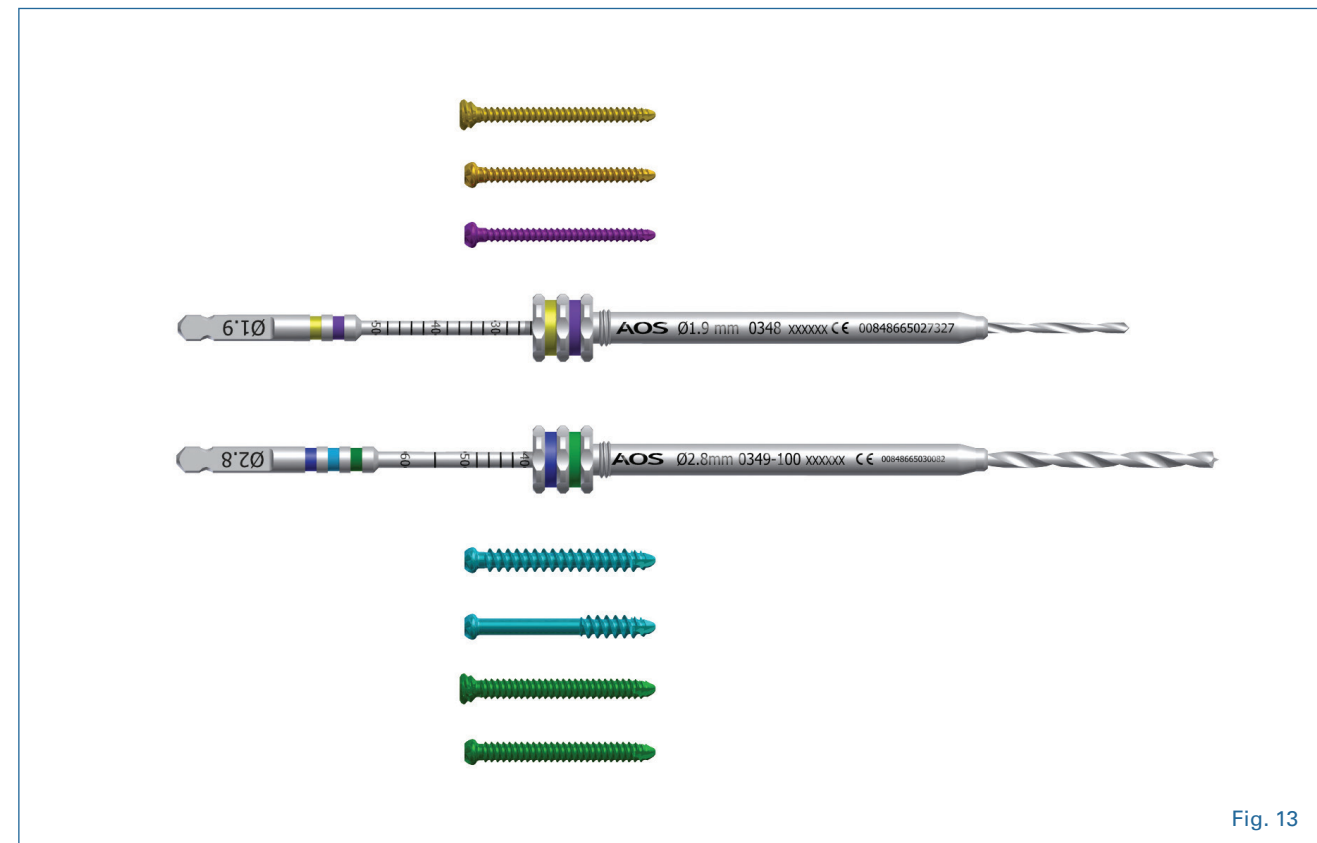

Once the desired screw type and diameter are selected, select the **Screw Sheath, Drill Guide** type and **Drill Bit** that coordinate with the color of diameter of screw to be placed.

Note: The color bands on the drill guides and drill bits coordinate with the color of the screw for easy matching intraoperatively (Fig. 13).

To use the fixed angle drill guide, select the fixed angle drill guide that coordinates with the screw type you plan to use.

Advance the drill guide into the plate screw hole until an audible snap is heard (Fig. 14). The coordinating drill bit can then be placed into the drill guide and the bone is drilled to the desired depth (Fig. 15).

To assemble variable angle drill guides, insert the variable angle drill guide into the screw sheath and thread it into the barrel of the screw sheath and hand tighten until it stops turning (Fig. 16).

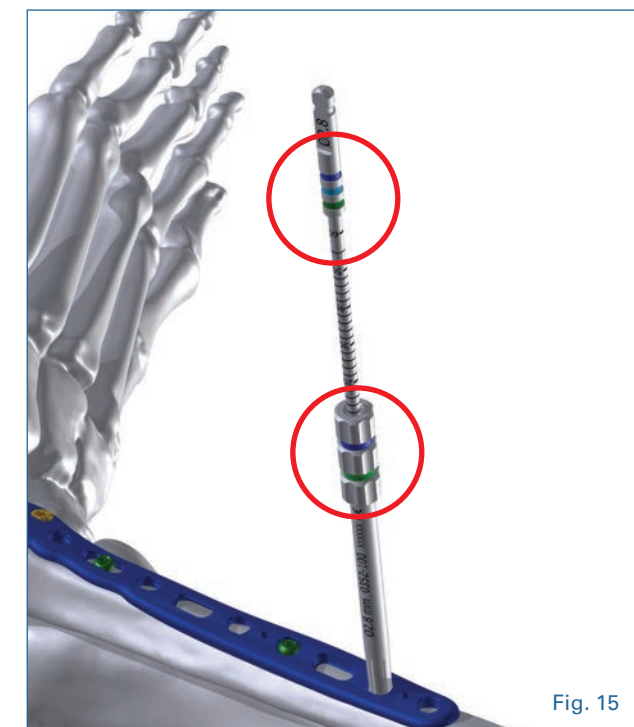

The screw sheath and drill guide assembly can then be placed into the desired screw hole and held at the angle at which the surgeon prefers up to 15° of angulation in any direction. The coordinating drill can then be placed into the drill guide and the bone is drilled to the desired depth (Fig. 17).

Note: Do not drill when the variable angle drill guide is at an

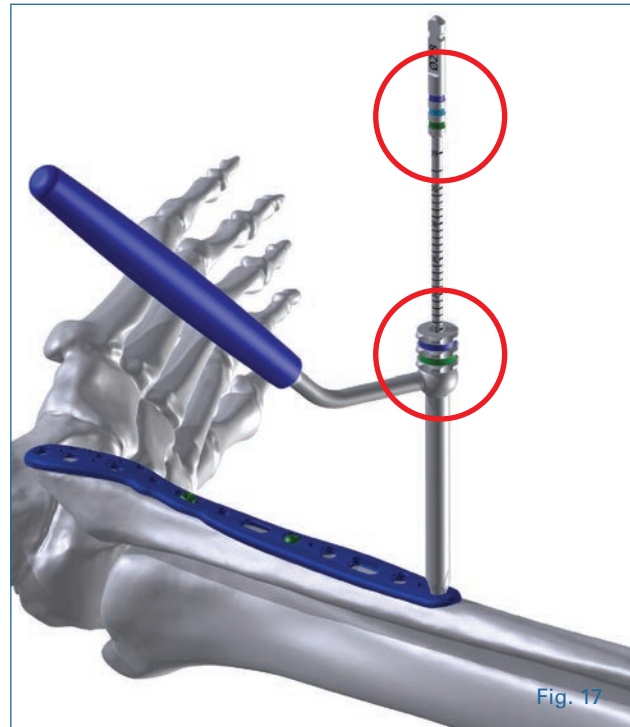

angle greater than 15° in any direction as this may cause the selected screw to not fully seat in the plate screw hole.

Note: The desired screw depth can be verified using radiographic imaging.

Once the desired screw depth has been drilled, measure for screw length using the depth gauge (Fig. 18) or graduated markings that are labeled on the drill (Fig. 19) for final screw length selection.

After all selected holes are drilled to desired depth, remove the drill guide. The screw sheath can remain in place with variable drill guide for screw placement.

Note: If preferred, a ratcheting torque limiting driver handle is available to use with driver.

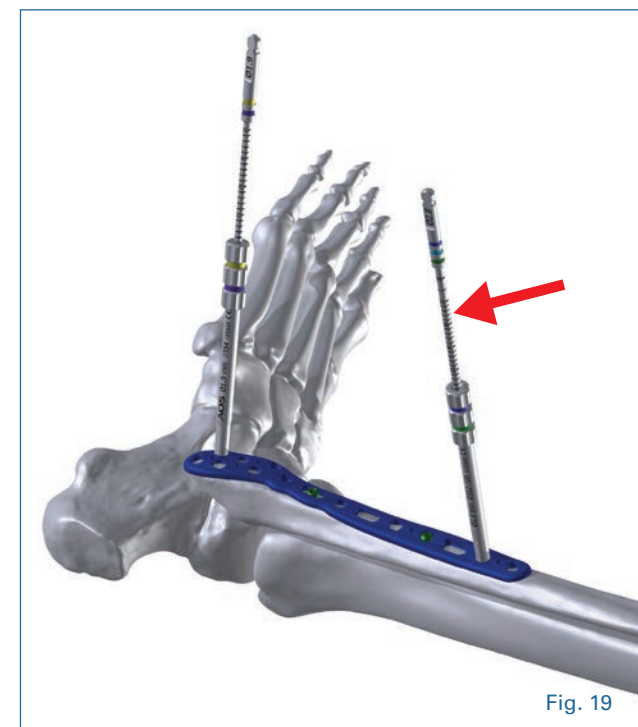
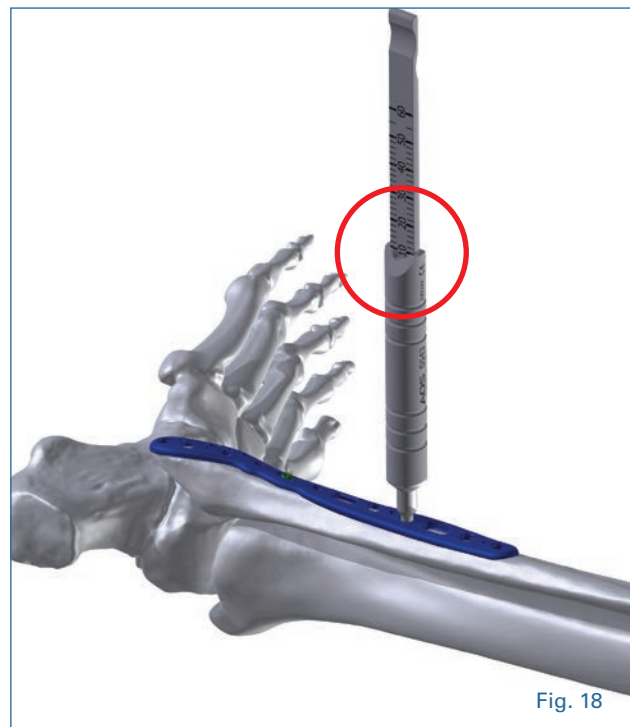

8. Non-Locking Screw

After you are satisfied with the fracture reduction and the temporary plate fixation and position, select the desired length locking screw based on the measurements recorded with depth gauge.

Note: The T10 Hexalobe Driver is designed so that the screw will stick to the drive for convenience in placing the screw. Make sure the driver is fully seated into the screw head.

Using the T10 Hexalobe Driver, insert the screw into the screw sheath and engage the screw into the bone. Once the screw is initially engaged into the bone, lift the screw sheath from the plate and continue to insert the screw until completely seated (Fig. 20a, 20b, 20c).

Note: Washers are included in the system and are designed to use with any of the non-locking screws when used as stand-alone screws. The washers should not be used with any screw when screws are placed into the plate screw hole.

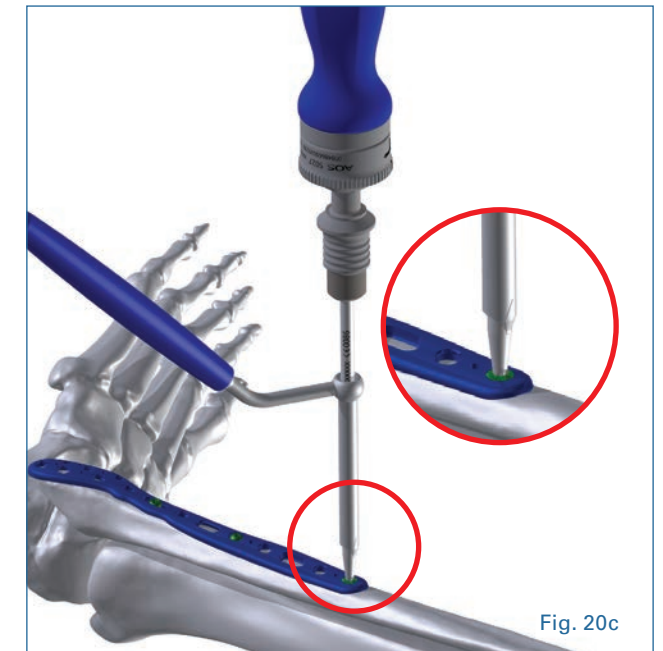

8. Locking Screw

Note: If a locking screw will be used as the first screw, be sure the fracture is reduced and the plate is held securely to the bone with one of the prior methods suggested in Section 4 "Reduction and Temporary Plate Fixation" (pg.7-9). This will help prevent the plate from undesired rotation as the locking screw is completely inserted and locked to the plate.

After you are satisfied with the fracture reduction and the temporary plate fixation and position, select the desired

length locking screw based on the measurements recorded with depth gauge.

Note: The T10 Hexalobe Driver is designed so that the screw will stick to the drive for convenience in placing the screw. Make sure the driver is fully seated into the screw head.

Using the T10 Hexalobe Driver, insert the screw into the screw sheath and engage the screw into the bone. Once the screw is initially engaged into the bone, lift the screw sheath from the plate and continue to insert the screw until completely seated (Fig. 20a, 20b, 20c).

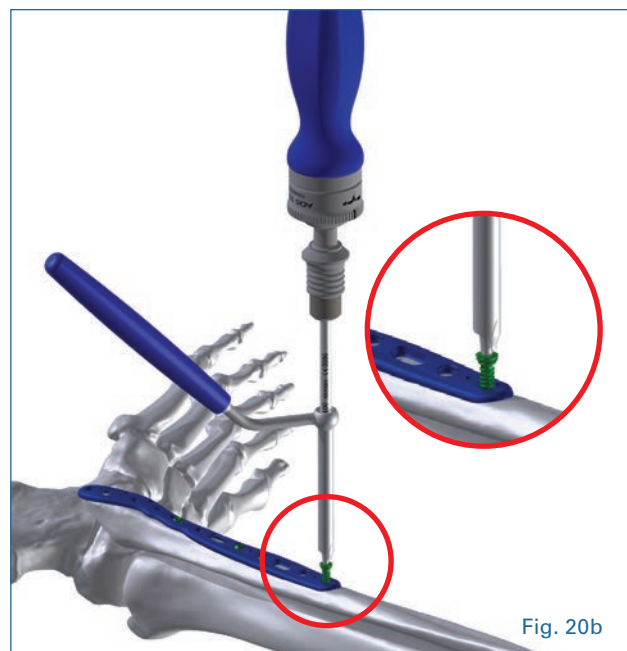
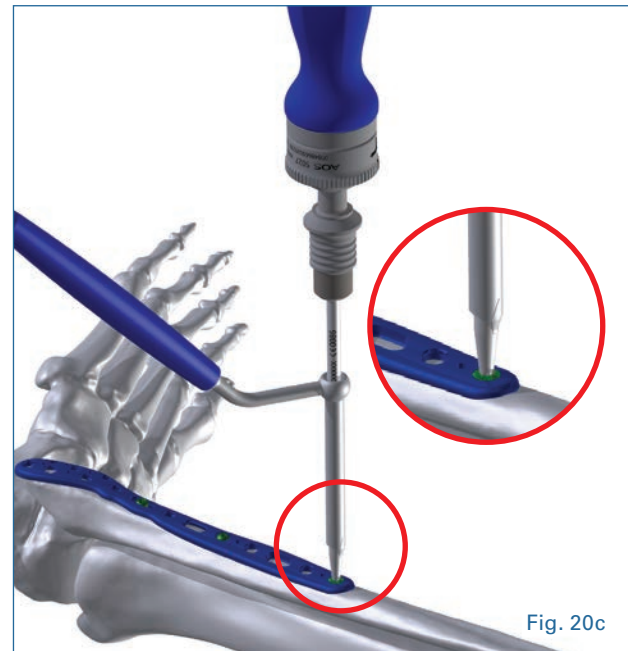

10. Cannulated Screw

If a cannulated screw is selected, it is designed to fit over the 1.5mm K-Wire. With the K-Wire in place and at the desired angle (Fig. 21), use depth gauge to measure desired screw length (Fig. 22). The T15 Hexalobe Driver is cannulated and should be used to drive the selected cannulated screw (Fig. 23) until it is fully seated (Fig 24).

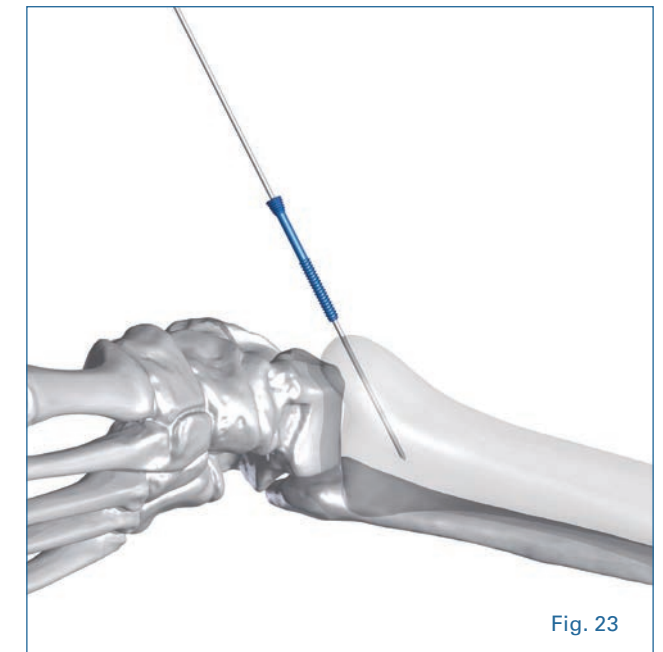
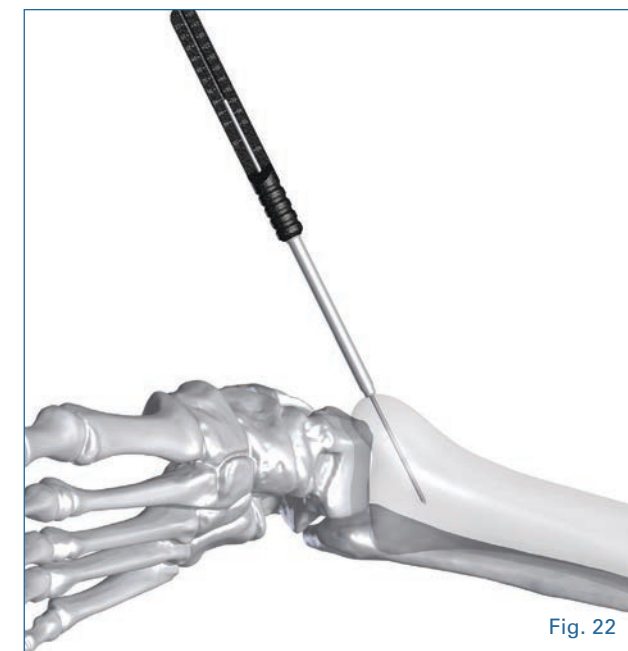
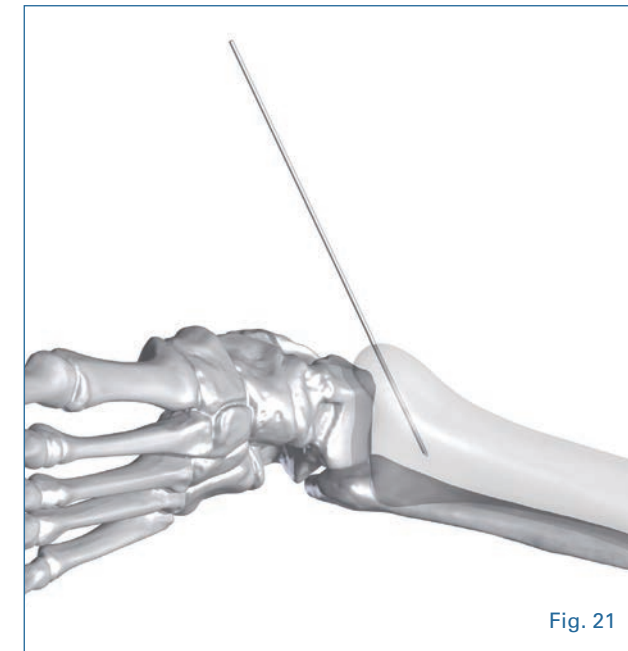

11. Confirm Reduction and Fixation

After all desired screws are securely placed and completely engaged, assess and confirm the final reduction and fixation by the appropriate placement and position of the plate and screws. This can be done by direct visualization and palpation of the plate and screws as well as radiographic imaging (Fig. 25).



12. Postoperative Treatment

Unless specific patient co-morbidity or other pathological injuries or conditions exists at the time of surgery, postoperative treatment with the Fibonacci Lower Extremity Plating System plates does not differ from other conventional internal fixation procedures.