

AOSTM

ADVANCED ORTHOPAEDIC SOLUTIONS

Retrograde

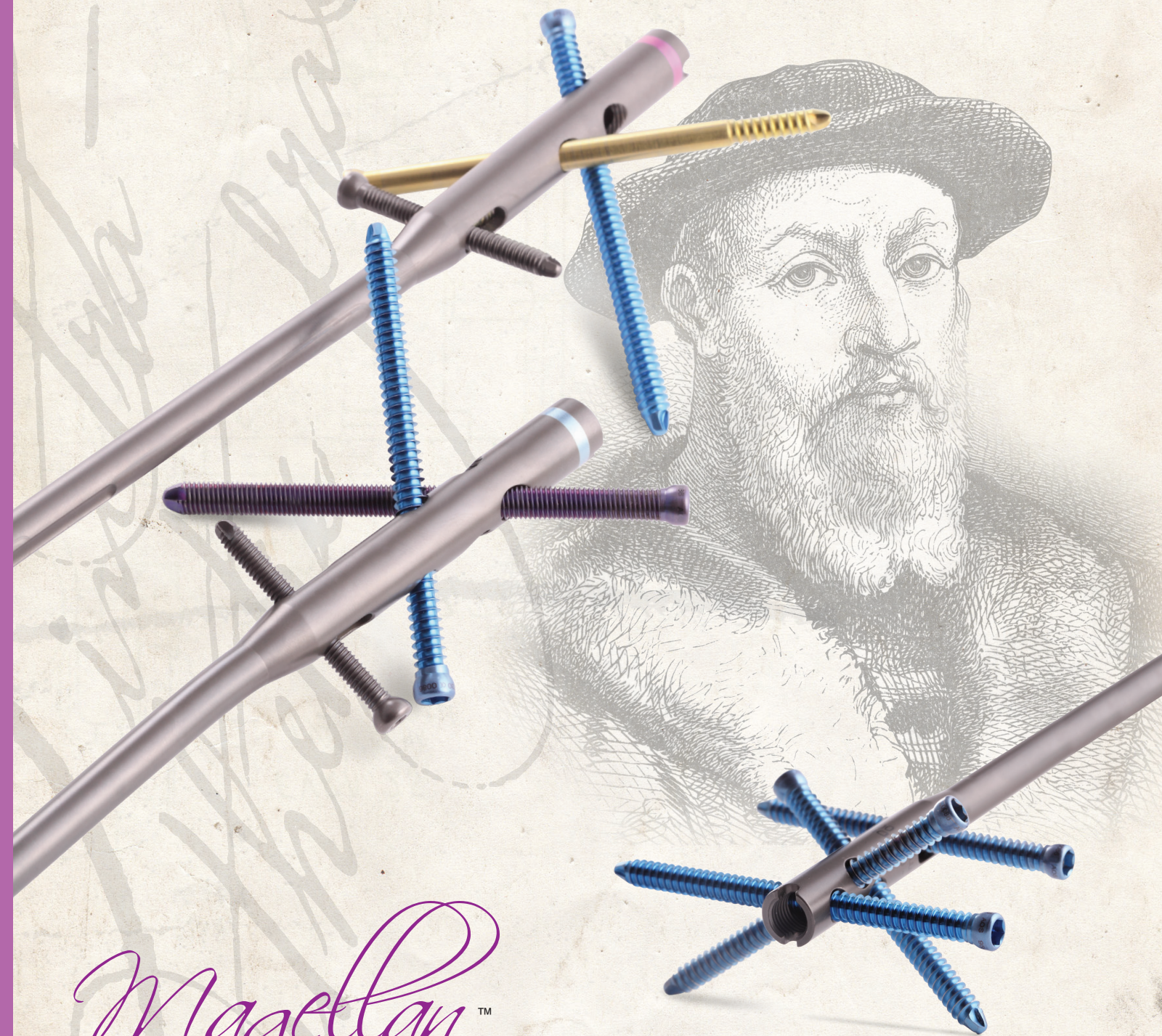

*Magellan*TM

FEMORAL NAIL SYSTEM
Surgical Technique

Advanced Orthopaedic Solutions
3203 Kashiwa Street
Torrance, CA 90505

T: 310.533.9966
F: 310.533.9876
www.aosortho.com

Follow us @



 Made in the USA

P/N: 9077 Rev B
©2015 Advanced Orthopaedic Solutions. All rights reserved.

Contents

IMPLANT FEATURES	2
1. INDICATIONS	3
2. PREOPERATIVE PLANNING	3
3. PATIENT POSITIONING	3
4. INCISION	3
5. ENTRY POINT	4
6. GUIDEWIRE INSERTION AND FRACTURE REDUCTION	5
7. NAIL SELECTION	5
8. NAIL ASSEMBLY AND INSERTION	5-7
9. PROXIMAL SCREW CONFIGURATIONS	8
10. PROXIMAL SCREW LOCKING	9-11
11. OBLONG HOLE LOCKING	11-12
12. CONDYLE NUT PROCEDURE	12-13
13. SHORT NAIL DISTAL TARGETING	14
14. LONG NAIL TARGETING - FREEHAND TECHNIQUE	15
15. END CAP INSERTION	15
16. POSTOPERATIVE CARE	15
17. NAIL EXTRACTION	15

This Surgical Technique sets forth detailed recommended procedures for using AOS devices and instruments. It offers guidance, but as with any such technical guide, each surgeon must consider the particular needs of each patient and make appropriate adjustments when and as required. Surgeons must always rely on their own professional clinical judgement when deciding which products and surgical treatments to use with their patients. Refer to package insert for information on indications, warnings, precautions and contraindications.

Retrograde Implant Features

Captured Cortical and Cancellous Screws (Proximal)

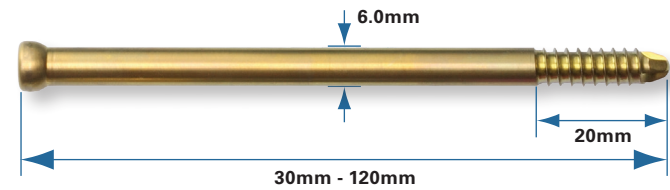
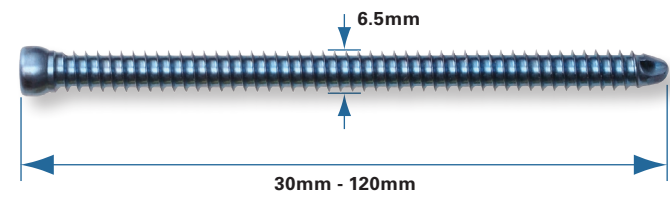
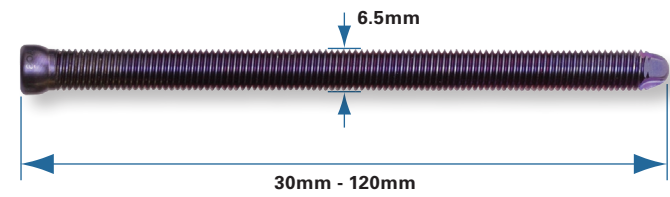

Captured Cortical Bone Screw (Distal) Locking Spacer

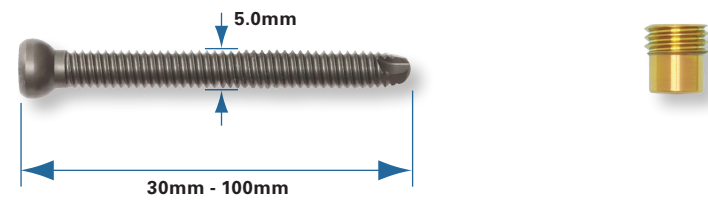

Condyle Fixation Nut & Washers



Captured End Caps



Retrograde Nail

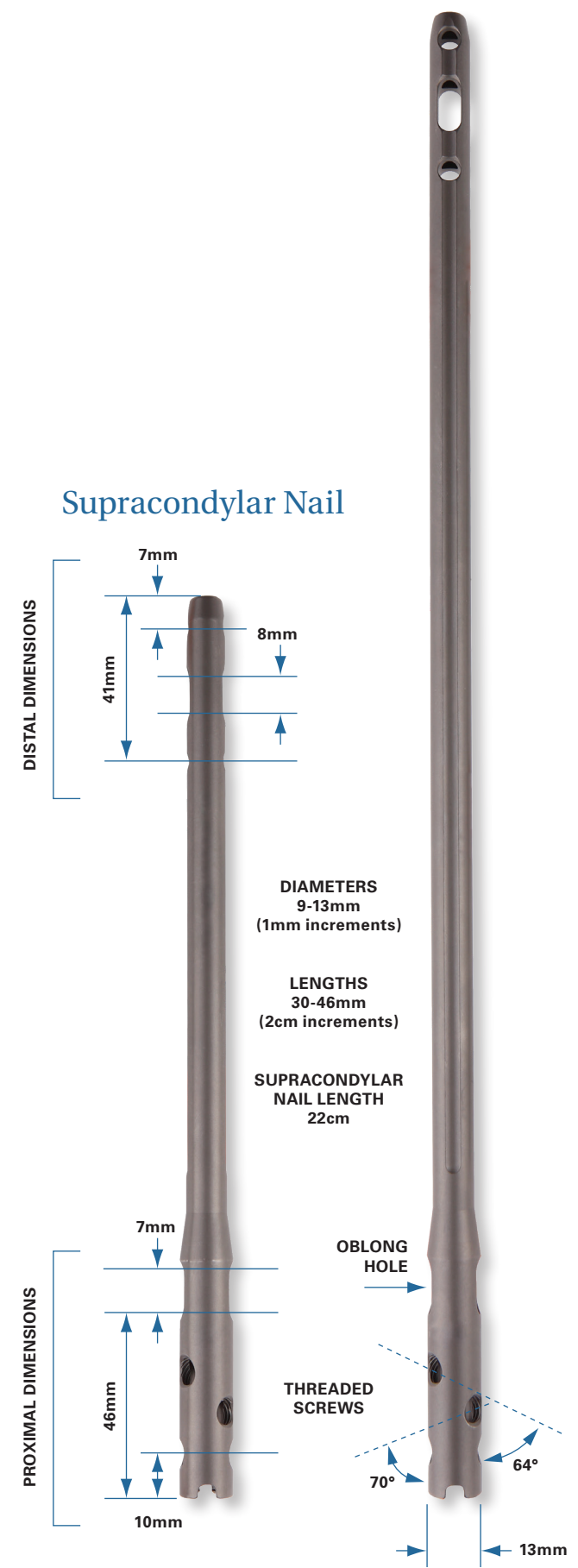

Magellan™ Retrograde Femoral Nail System Surgical Technique

1. Indications

The AOS Retrograde Femoral Nail is intended for use in intramedullary fixation of fractures of the femur to include the following:

- Supracondylar fractures, including those with severe comminution and intraarticular extension
- Open and closed femoral fractures
- Pseudoarthrosis and correction osteotomy
- Pathologic fractures, impending pathologic fractures, and tumor resections
- Bone lengthening
- Fractures distal to a total hip prosthesis
- Nonunions and malunions
- Fractures resulting from osteoporosis

2. Preoperative Planning

Preoperative planning is recommended before beginning the surgical procedure. A/P and Lateral x-rays of the injured femur should be taken preoperatively and evaluated for nail length, canal size, expected amount of reaming, and screw length. A/P and Lateral x-rays of the contralateral uninjured femur can also be taken preoperatively to provide insight into the characteristics of the pre-injured femur.

3. Patient Positioning

The patient should be positioned in a supine position on a radiolucent table with the injured leg draped free and a bump under the ipsilateral hip. The C-arm should be positioned to allow imaging of the femur in both planes along the entire length of the bone. Place the knee on a sterile bolster to maintain approximately 45° of flexion (Fig. 1). Use manual distraction or a femoral distractor to reduce severely displaced fractures and to restore length.

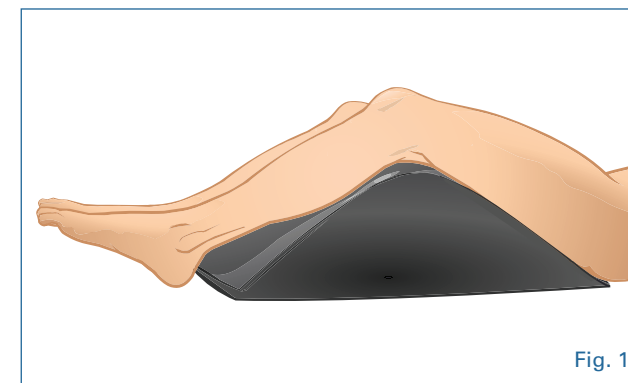

4. Incision

Approach the distal femur through one of two incisions. Make a longitudinal incision from the inferior/medial aspect of the patella to the level of the tibial tubercle, along the medial border of the patellar tendon. Obtain access to the intercondylar notch by making a small medial para-patellar incision and retracting the patellar tendon laterally (Fig. 2).

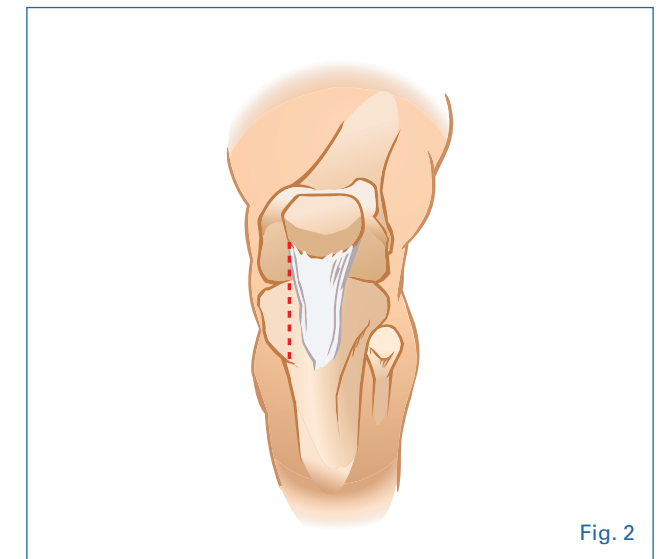

Alternatively, make a longitudinal midline incision from the inferior patella to the tibial tubercle. Obtain access to the intercondylar notch by splitting the patellar tendon longitudinally in its midline (Fig. 3).

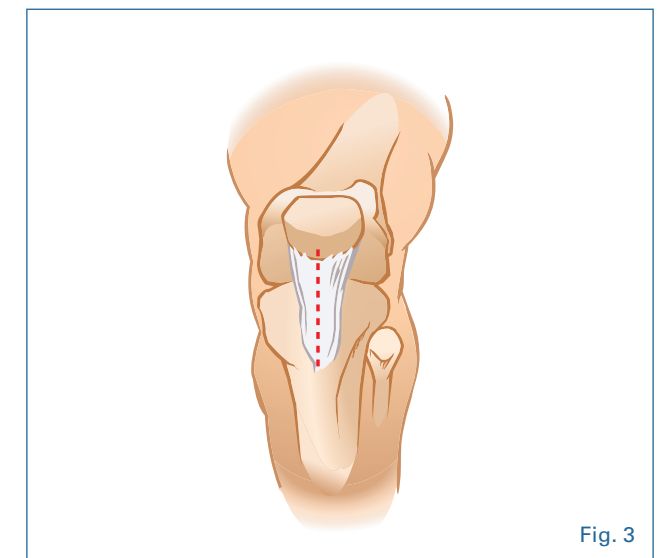

5. Entry Point

The entry point for the nail is located in line with the femoral canal on the A/P view, and just anterior to where Blumensaat's line intersects the anterior intercondylar notch on the lateral view (Fig. 4 and Fig. 5).

Option 1

Assemble the **3.2mm Pin Guide** into the **Soft Tissue Protector** and place it through the incision. Align the Soft Tissue Protector with the femoral shaft on the A/P and lateral image views and insert a 3.2mm Guide Pin (Fig. 4 and Fig. 5).

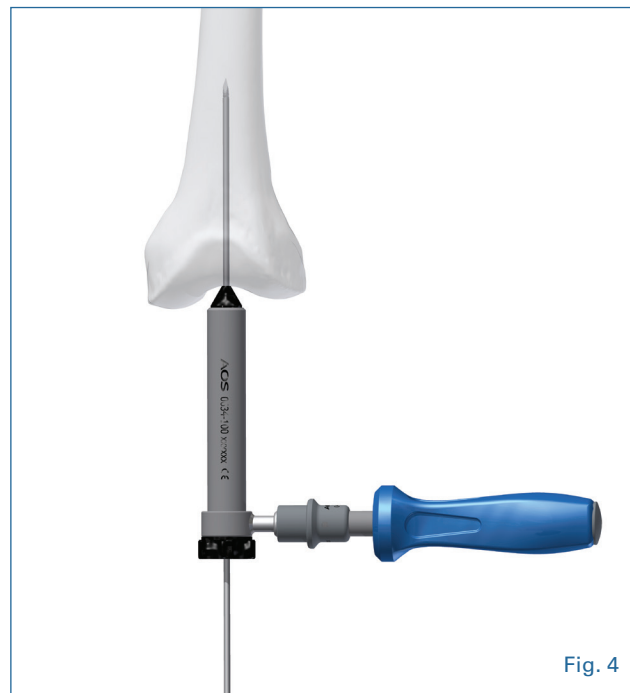

Fig. 4

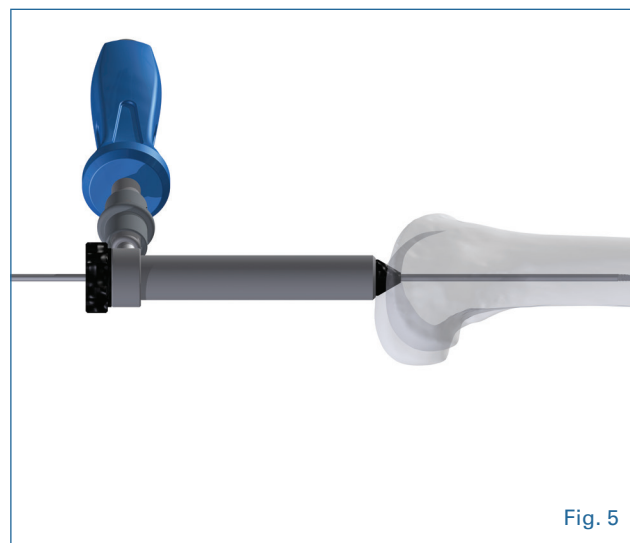

Fig. 5

Place the **13.5mm Cannulated Entry Reamer** over the guide pin and ream the distal femur through the **Soft Tissue Protector** (Fig. 6). This leaves 0.5mm clearance around the distal portion of the nail. The entry reamer has depth indication grooves which are read from the top of the **Soft Tissue Protector**. The depth grooves allow for the nail to be placed flush or 5mm deep. The C-arm should be used to visualize the depth of the reamer in the distal femur. Care should be taken to keep the reamer in line with the shaft of the femur to avoid reaming through the cortex of the femur.

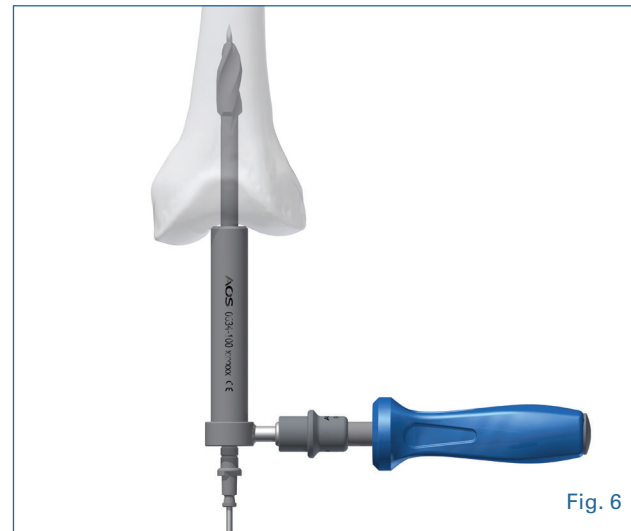

Fig. 6

Option 2

Alternatively, the surgeon may open the entry point with a **Cannulated Curved Awl** followed by a **3.0mm Ball Nose Guidewire** that is placed through the curved awl to the desired depth (Fig. 7). The curved awl is then removed from the bone allowing the guidewire to stay properly positioned.



Fig. 7

6. Guidewire Insertion and Fracture Reduction

It is critical to achieve anatomic reduction before beginning any of the steps to insert the nail. Traction should be used as necessary to help achieve fracture reduction.

To assist in fracture reduction, a **Curved Reduction Tool** and Handle may be utilized. Introduce the **3.0mm Ball Nose Guidewire** by means of the **Guidewire Gripper** to the level of the fracture (Fig. 8a and Fig. 8b). Confirm its containment within the femur by means of A/P and lateral views. Reduce the distal fragment to the proximal fragment and advance the guidewire until it is centered in the proximal femur. Verify containment of the guidewire within the femur by image intensification.

NOTE: It may be necessary to open up the intramedullary canal to the fracture with flexible reamers to accommodate insertion of the **9.5mm Curved Reduction Tool**.

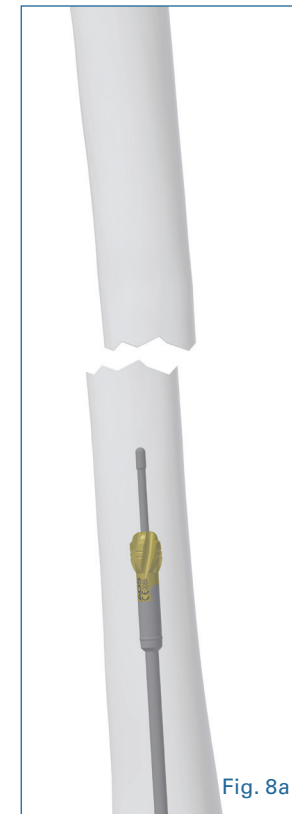

Fig. 8a

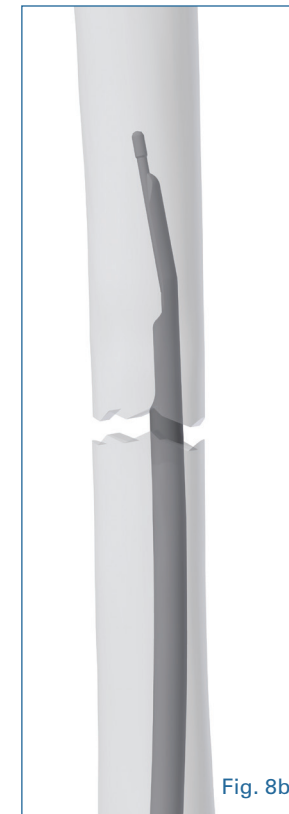

Fig. 8b

For reaming the femur, use the **Flex Shaft** and **Reamer Heads** (9.5mm-16.5mm) over the **3.0mm Ball Nose Guidewire**. Ream the entire femur in 0.5mm increments until a desired diameter of at least 1.0-1.5mm is larger than the anticipated nail diameter. The **3.6mm Obturator** can help prevent the guidewire from backing out of the femur during reaming.

NOTE: Never insert a nail that has a larger diameter than the last reamer used.

7. Nail Selection

The proper nail length is determined by sliding the **Guidewire Depth Gauge** over the guidewire to the level of the intercondylar notch and reading the appropriate length directly from the calibrated line on the guidewire (Fig. 9). Alternatively, a **Radiographic Ruler** may be used with a C-arm to estimate nail length.

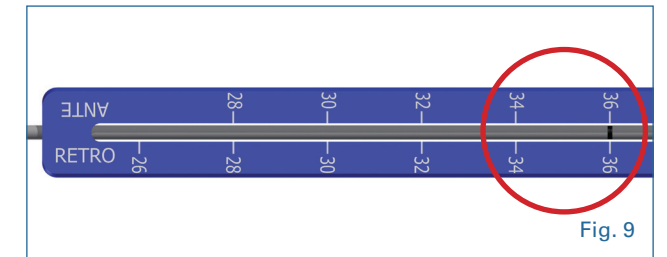

Fig. 9

8. Nail Assembly and Insertion

If controlled compression is desired using the proximal oblong hole, a **Compression Spacer** should be inserted into the proximal end of the nail using a **5.0mm Compression Hex Driver** and **T-Handle**. This must be done prior to assembling the nail to the targeter.

To utilize controlled compression, the compression spacer should be inserted past the oblique holes, but proximal to the oblong hole (Fig. 10).

Compression Spacer (Optional)



Fig. 10

Attach the **Retrograde Radiolucent Targeting Guide** to the nail using the **Connection Bolt, T-Handle, and Ball Hex Driver**. If using oblique screws, the **Retrograde Targeting Guide Arch** should be attached to the main body (**Fig. 11**). The **Impactor Pad** should be used if impaction is necessary. Use a **Screw Sheath, 3.2mm Pin Guide, and 3.2mm Obturator** to verify that the holes in the guide align with the holes in the nail, before insertion of the nail.

Introduce the nail into the femur using the **Retrograde Radiolucent Targeting Guide**. If a guidewire is used, pass the nail over the guidewire (**Fig. 12**). If the nail does not enter the femur easily, apply a gentle blow to the **Impactor Pad** with the use of a mallet. It is very important to **NEVER HIT** directly on the radiolucent targeting guide. Monitor the progression of the nail using the C-arm, especially as the nail is passing through or near the fracture site.

NOTE: Avoid the use of excessive force which may produce comminution of the femoral shaft.

If the nail will not advance with impaction, remove the nail and ream the canal to a larger diameter in 0.5 mm increments or consider using a smaller diameter nail. Using the lateral C-Arm image, countersink the nail at least 3-5mm inside the articular surface of the femur.

Remove the ball tip guidewire from the nail using the **Guidewire Gripper**. If possible, the guidewire should be removed before the nail is completely seated to reduce the potential for the wire to get caught in the nail. If the wire is difficult to remove, rotate the wire 90° with the guidewire gripper while pulling the wire.



Fig. 11



Fig. 12

9. Proximal Screw Configurations

Multiple screw configuration patterns can be utilized (Fig. 13).

NOTE: If controlled compression is desired using the oblong hole, this should always be the first screw inserted. (See section 11, Pg. 11).

The available screws for the proximal end of the nail are the **6.0mm Partially Threaded Cancellous Screw**, **6.5mm Fully Threaded Cortical Screw** and **6.5mm Fully Threaded Cancellous Screw**, and **5.0 Fully Threaded Cortical Screw** (Table 1).

NOTE: The 6.5mm fully threaded cancellous and cortical screws both thread into the most proximal transverse hole and the two oblique holes, preventing screw back out.

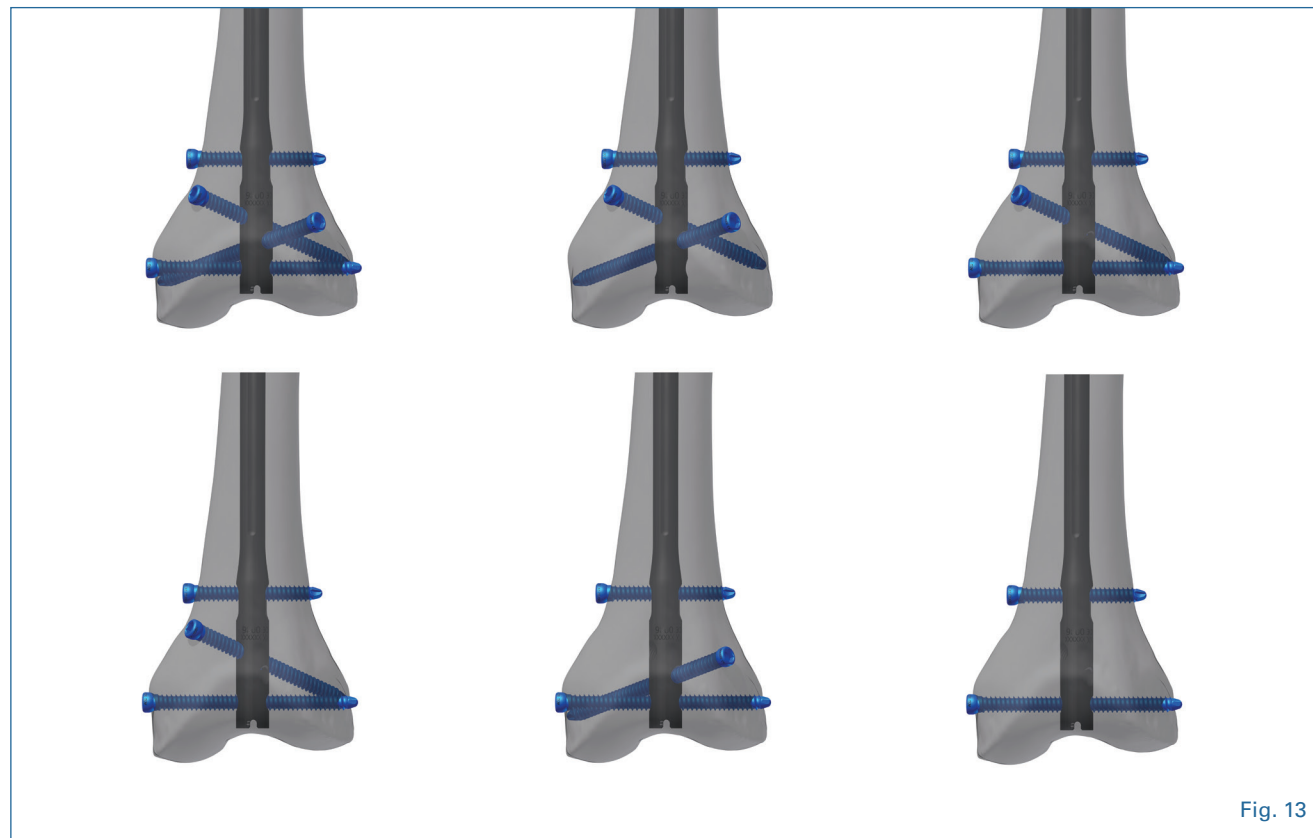





Fig. 13

TABLE 1	Type	Diameter	Drill
	Partially Threaded Cancellous	6mm	4.8/6.0mm Calibrated Step (Yellow)
	Fully Threaded Cancellous	6.5mm	5.5mm (Blue/Purple)
	Fully Threaded Cortical	6.5mm	5.5mm (Blue/Purple)
	Fully Threaded Cortical	5.0mm	4.0mm (Green)

10. Proximal Screw Locking

There are two techniques for insertion of the **6.5mm Fully Threaded Cancellous Screw (BLUE)** and **6.5mm Fully Threaded Cortical Screw (Purple)**.

Option A

Use a solid drill to pre-drill for the screw. Thread a **Locking Collet** into the desired screw location. Insert the **Screw Sheath**, the **Drill Guide**, and the **Obturator** through the targeting module and locking collet and mark the incision location on the skin. Make a small incision, insert the sheath, drill guide, and obturator until it contacts the cortex of the femur (Fig. 14). After positioning the sheath and drill guide, turn the **Locking Collet** clockwise to lock the drill guide in place.

NOTE: Alternatively, the **Sheath** and **Drill Guide** may be used freely without utilizing the **Locking Collet**.



Fig. 14

Remove the obturator, and use the **5.5mm Calibrated Drill** to drill to the desired depth. With the screw sheath up against the bone, read the calibrations on the drill for the appropriate screw length. For bicortical screws, the **Hook Tip Depth Gauge** may also be used for determining the screw size.

Assemble the appropriate screw onto the **Captured Screw Driver System** and **T-Handle** as shown in Fig. 16. Insert and advance the screw to the desired location.

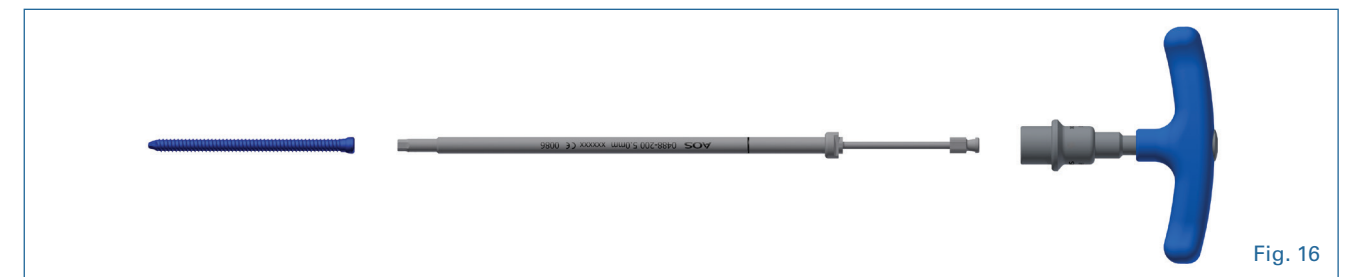

Fig. 16

In dense bone it is advisable to tap the femur before placing the screws. After drilling, remove the drill guide and tap the bone using the **6.5mm Calibrated Cancellous or Cortical Tap**.

Option B

This option allows the use of guide pins to plan the location of the screws prior to drilling with a cannulated drill. Thread a **Locking Collet** into the desired screw location. Insert the **Screw Sheath**, **3.2mm Pin Guide**, and **3.2mm Obturator** through the targeting guide and mark the incision location on the skin. Make a small incision, insert the sheath, pin guide, and obturator until it contacts the cortex of the femur. After positioning the sheath and pin guide, turn the **Locking Collet** clockwise to lock the pin guide into place.

NOTE: Alternatively, the **Sheath** and **Pin Guide** may be used freely without utilizing the **Locking Collet**.

Remove the obturator and place a **3.2mm Guide Pin** into the **Pin Guide** and insert it to the desired depth. Place the **Guide Pin Depth Gauge** against the pin guide. Read the length from the depth gauge, while verifying that the pin guide is touching the bone (Fig. 15). The **Pin Guide** is then taken out of



Fig. 15

the **Screw Sheath** and a **5.5mm Calibrated Cannulated Drill (BLUE/PURPLE)** is inserted over the guide pin. The femur is then drilled to the appropriate depth and screw length is read off of the calibrated drill bit, using the screw sheath as a reference.

Assemble the appropriate screw onto the **Captured Screw Driver System** and **T-Handle** as shown in Fig. 16.

Insert and advance the screw to the desired location. Remove the **3.2mm Pin Guide** from the screw sheath and advance the screw to the desired location.

In dense bone, it is advisable to tap the femoral head before placing the screws. After drilling, remove the **3.2mm Guide Pin** and tap the bone using the **6.0mm Calibrated Cancellous Tap** or **6.5mm Calibrated Cortical Tap**.

Repeat this technique to place additional screws as necessary.

For use of 6.0mm Partially Threaded Cancellous Screws

Insertion requires the use of a **4.8/6.0mm Calibrated Step Drill**. Thread a **Locking Collet** into the desired screw location. Insert the **Screw Sheath**, **Drill Guide**, and **Obturator** through the targeting module and locking collet and mark the incision location on the skin. Make a small incision, insert the sheath, drill guide, and obturator until it contacts the cortex of the femur (**Fig. 17**). After positioning the sheath and drill guide, turn the **Locking Collet** clockwise to lock the drill guide in place.



Fig. 17

NOTE: Alternatively, the **Sheath** and **Drill Guide** may be used freely without utilizing the **Locking Collet**.

Remove the obturator and use the **4.8/6.0mm Calibrated Step Drill** to drill to the desired depth. With the screw sheath up against the bone, read the calibrations on the drill for the appropriate screw length. For bicortical screws, the **Hook Tip Depth Gauge** may also be used for determining the screw size.

11. Oblong Hole Locking

Prior to insertion of any screws, the surgeon must determine whether the oblong hole will be used for controlled compression or standard locking.

Option A:

For static locking, advance the **Compression Spacer** to the top of the oblong hole using the **5.0mm Compression Hex Driver** and **T-Handle**. Insert the desired screw into the distal end of the slot (**Fig. 18**), as previously described.

To utilize compression the locking spacer should be appropriately positioned inside the nail at this point.

For Standard Locking: Use of either the static hole or the **Comp/Stat** hole can be selected per surgeon preference. Accomplish locking with 6.0mm or 6.5mm screws as previously described.

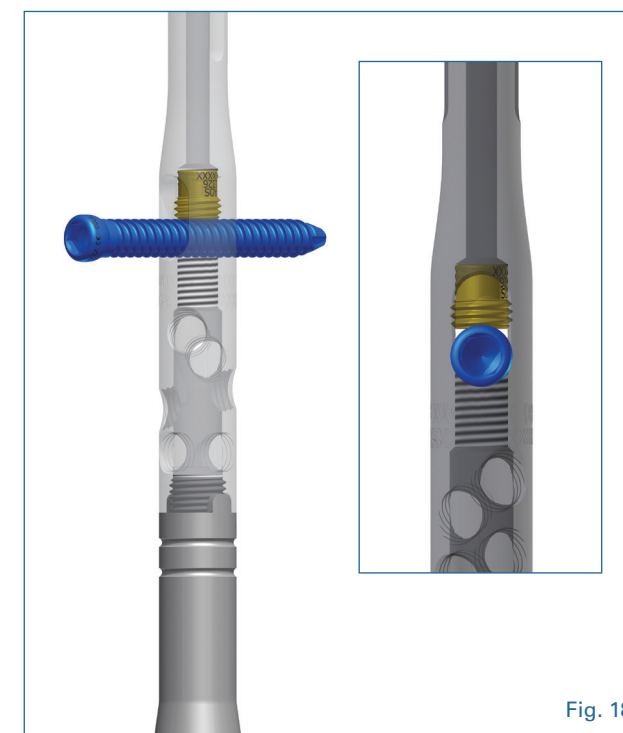

Fig. 18

Option B:

For controlled compression, it is important to countersink the nail by at least 10mm to avoid backing the nail out into the joint. Utilize the **Comp/Stat** hole to place a 6.0mm or 6.5mm screw as previously described. Then, place one or more **5.0mm Cortical Screws** in the distal holes as described in section 13 and 14 (**Fig. 19**).

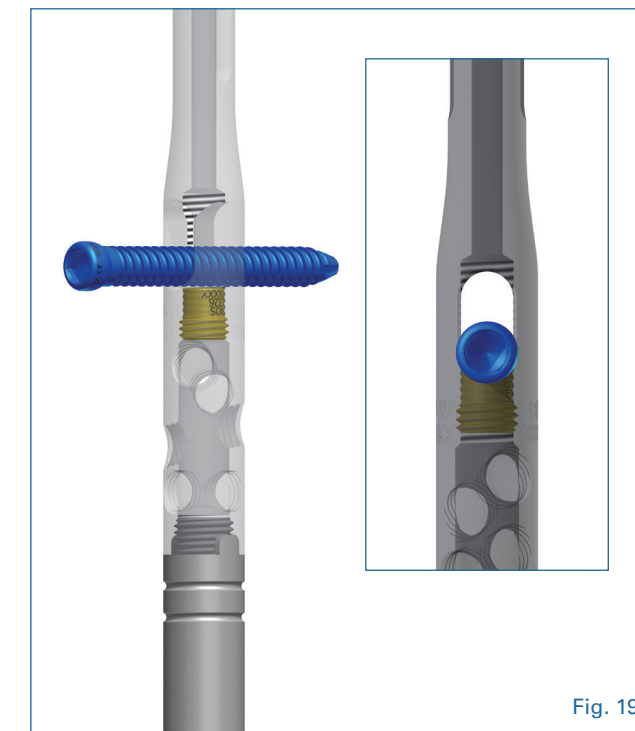

Fig. 19

Use the **5.0mm Compression Hex Driver** to drive the **Compression Spacer** up against the transverse screw within the oblong hole. This will draw the distal segment of the femur (**Fig. 20**). Turn the **5.0mm Compression Hex Driver** and **T-Handle** clockwise to compress the fracture up to **7.0mm** or when the screw is at the most distal end of the slot.

WARNING: Do not over-tighten the Compression Spacer during controlled compression as this may damage or deform the screw. Monitor the fracture site and the screws on the proximal and distal ends of the nail under fluoroscopy when using the compression feature.

12. Condyle Nut Procedure

To compress a fracture with intra-articular extension into the condylar area, a **Condyle Nut** may be used in conjunction with a transverse interlocking screw.

NOTE: Only the transverse locking holes can be used with this feature.

Reduce the condylar fracture using reduction clamps or K-wires (not included). Set up the targeting guide for placement of a transverse interlocking screw. Using the techniques previously described, place a 6.0mm or 6.5mm transverse interlocking screw.

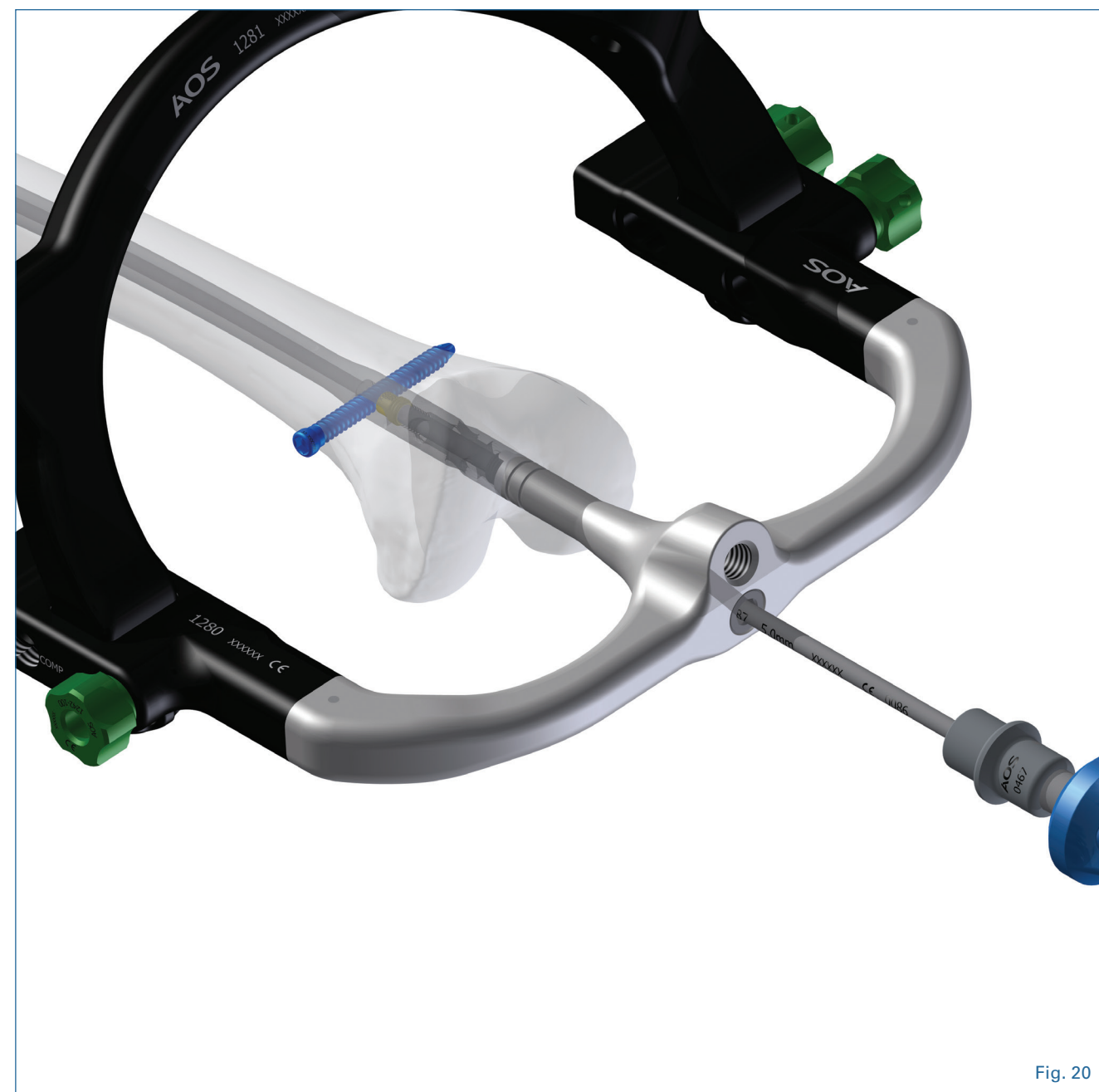

Fig. 20

Drill both cortices into the desired transverse location (**Fig. 21**). Note the calibration for the screw length when the drill has just reached the far cortex. Do not remove the drill. Assemble the **Condyle Nut**, **Hex Driver**, and **Condyle Locking Collet** as shown in (**Fig. 22**). Using the hole location on the targeting guide directly across from where the drill was inserted, loosely thread a **Condyle Locking Collet** into place. Next, use the **5.0mm Hex Driver** to insert a **Condyle Nut** through a **Nut Washer** and advance it into the far cortex over the tip of the drill bit. Advance the **Condyle Nut** until the **Nut Washer** is flush against the outer cortex of the bone. The use of C-arm can verify this docking of the Condyle Nut and Nut Washer over the tip of the drill bit. Turn the **Condyle Locking Collet** clockwise until it is snug, keeping the **5.0mm Hex Driver**

engaged with the **Condyle Nut** (**Fig. 23**). Remove the drill bit and select a screw that is **5.0mm shorter** than the measured length. Use the **5.0mm Hex Driver** to insert the selected screw into the targeting guide, through a **Screw Washer**, and into the bone. Advance the screw across the condyles, through the nail, and into the **Condyle Nut**. Apply compression across the fracture until the washers on each side of the condyles are flush with the bone (**Fig. 24**).

NOTE: Use caution when docking the screw with the **Condyle Nut** so as not to cross thread the screw or overcompress the construct. Use the C-arm to verify appropriate placement of the screw and compression of the fracture.

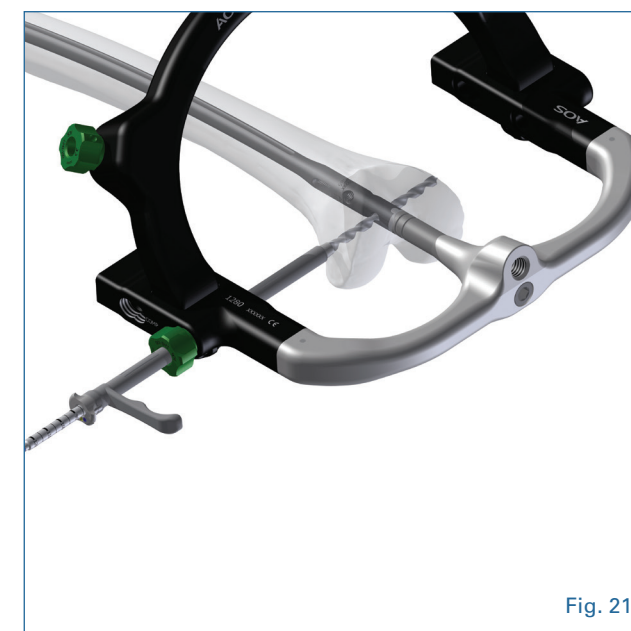

Fig. 21

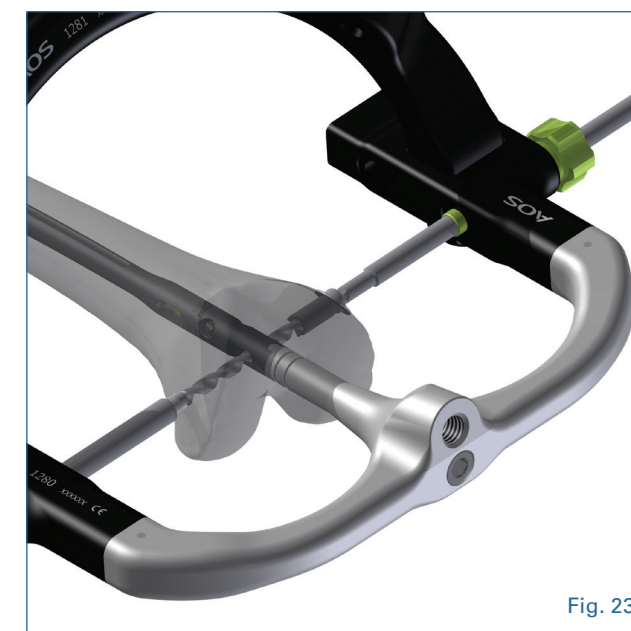

Fig. 23

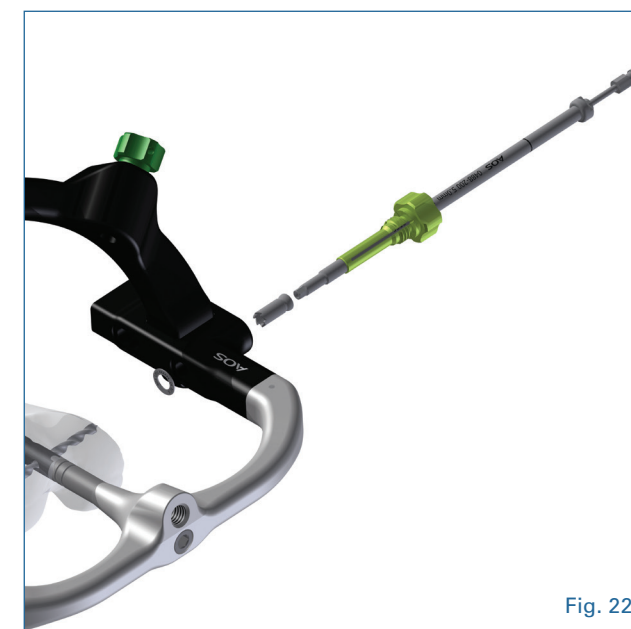

Fig. 22

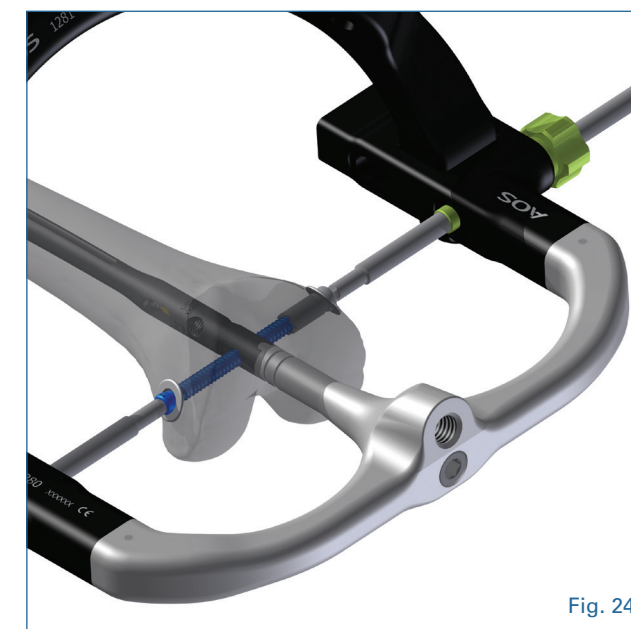

Fig. 24

13. Short Nail Distal Targeting

The distal locking holes on the 22cm Short Retrograde Femoral Nails are transverse holes that are targeted using extensions to the targeting guide. These holes on the nail are threaded to lock the 5.0mm Cortical Screws to the nail. Attach the extension piece by aligning the pins and threading the bolt to the desired side (Fig. 25). Insert the **Screw Sheath**,

4.0mm Drill Guide, and **4.0mm Obturator** through the targeting guide and make the incision location on the screw. Make a small incision, insert the **Sheath**, the **Drill Guide**, and the **Obturator**. Drill both cortices using the **4.0mm Calibrated Drill**. Read the calibration for the length of the screw and insert the screw using a 5.0mm Hex Driver. Both static and dynamic locking options are possible.

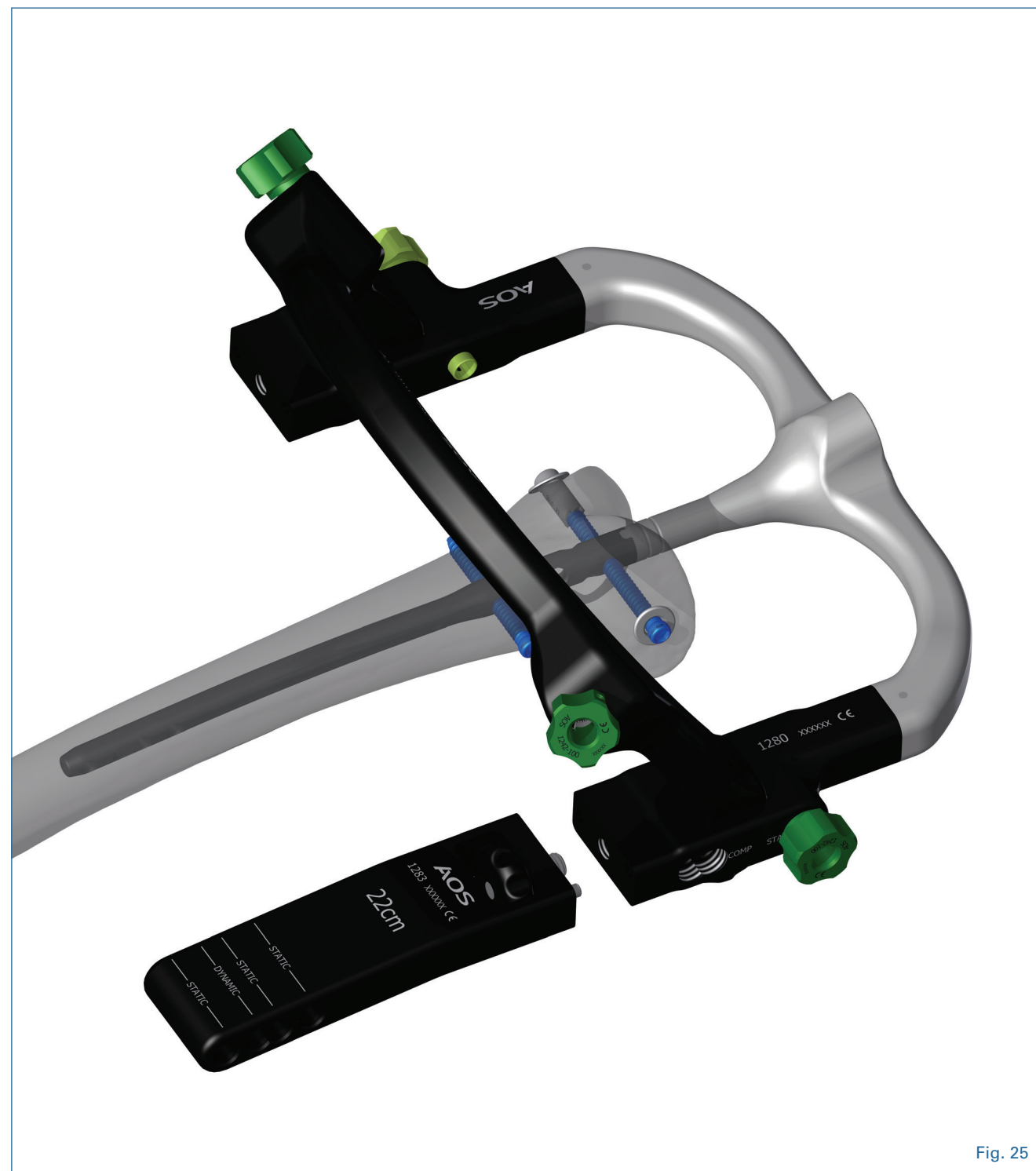

Fig. 25

14. Long Nail Targeting – Freehand Technique

Freehand technique is used to insert **5.0mm Cortical Screws** in the anterior/posterior holes in the distal end of the nail. Both static and dynamic locking options are possible (Fig. 26). Rotational alignment must be checked prior to insertion of these screws.

Locking is accomplished using a freehand technique. Accurate C-arm position is confirmed when the nail holes appears to be perfect circles on the A/P view. Once the correct location has been verified fluoroscopically, make an incision in direct alignment with the hole. Drill until the second cortex is penetrated. Verify the drill bit position fluoroscopically prior to taking any measurements.

The screw length is measured from the calibrated line on the **4.0mm Short Drill** using the **Distal Depth Gauge**. Alternatively the **Hook Tip Depth Gauge** can be used. Use the **Short or Long 5.0mm Captured Hex Driver System** to insert the cortical screw.

The retrograde femoral nail can also be used in a dynamic locking mode when the fracture pattern permits. Dynamic locking may be utilized for transverse or rotationally stable fractures patterns without comminution. This is performed by placing a **5.0mm Cortical Screw** in the dynamic (distal) position of the oblong hole. This allows the nail to move and the fracture to settle while torsional stability is maintained. If immediate dynamization of the nail is desired do not fill any of the static holes.



Fig. 26

15. End Cap Insertion

If use of an end cap is desired, determine if the depth of nail has been countersunk by using the lateral x-ray of the nail. Using the **T-Handle** and **5.0mm Captured Hex Driver System** to capture the end cap. Insert the appropriate end cap through the proximal incision into the nail.

If a **6.0mm Partially Threaded Cancellous Screw** is used in the most proximal transverse locking hole of the nail, a **0mm End Cap** may be used to prevent lateral migration of the screw.

16. Postoperative Care

Early range of motion of the hip and knee and mobilization of the pattern are encouraged. Allow weight bearing to progress to full weight bearing as indicated by fracture pattern and radiographic healing.

It is the responsibility of the surgeon to determine the most suitable postoperative care.

17. Nail Extraction

Locate the proximal end of the nail and use the **5.0mm Hex Screwdriver** to remove the end cap if one was inserted. Insert the **Extraction Bolt** in the proximal end of the nail (**Note:** Attachment of the **Extraction Bolt** is recommended prior to removal of interlocking screws). Use C-arm to locate any distal screws. Expose the screws and use a **5.0mm Hex Screwdriver** to remove them. If bone has grown into any of the screws, nail cap or nail that would inhibit implant removal, use instruments such as rongeurs, dental picks, or small curettes to remove bone before attempting implant removal. Take care not to damage the implants while removing ingrown bone.

To extract the nail attach the **Impactor Pad** to the **Extraction Bolt**. Then apply gentle backward blows with a mallet. Be careful to avoid levering the nail/extractor assembly during removal. Use C-arm to visualize removal of the nail to avoid unnecessary damage to the femur.

